

CARMINATI
MORSE

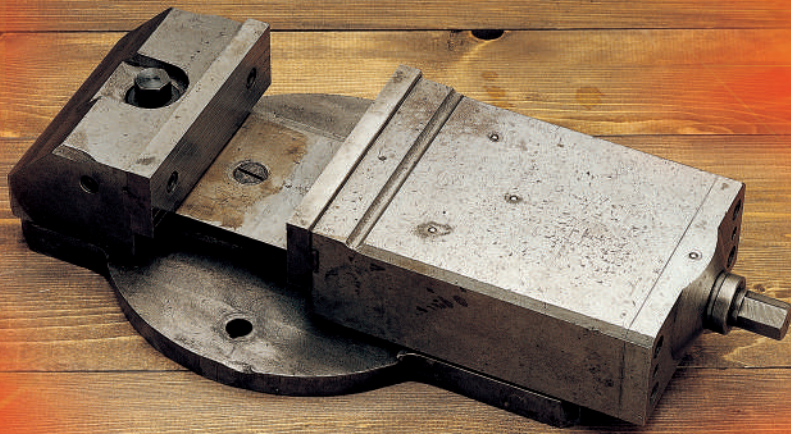



Noi della "CARMINATI MORSE", ci occupiamo da sempre della produzione di morse e, grazie alla preferenza accordataci dalla nostra clientela e al nostro costante impegno nella ricerca di soluzioni tecnologicamente avanzate, siamo orgogliosi di proporVi le ultime novità Carminati. Queste nuove morse, sono state concepite principalmente per risolvere i problemi

legati ai centri di lavoro a controllo numerico, con la stessa precisione e serietà che caratterizzano tutta la produzione Carminati. Oltre a questa nuova serie, la Carminati, è a Vs. disposizione con la sua già collaudata gamma di morse, che vanta un sistema tutto proprio ed esclusivo, tale da garantire agli utilizzatori risultati ineccepibili nelle più varie e specialistiche necessità produttive di precisione.

Our firm "CARMINATI MORSE" since ever is occupied in the production of vices.















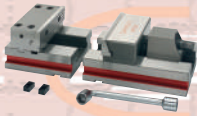









Thanks to the preference of our customers, and our constant engagement in technological evolutions, we are now proud to propose the last news from CARMINATI.

These new vices, have been mainly conceived to resolve problems connected with numerical control working centers, with the same precision and reliability that characterize the whole production of CARMINATI.

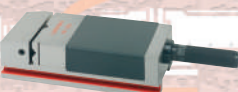
Besides this new series, the CARMINATI FIRM is at your disposal with it's already tested series of exclusive vices to guarantee unexceptional precision results according necessity.

INDICE / INDEX

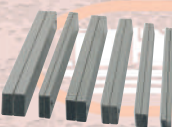

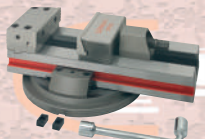
	CUBI TIPO / CUBE TYPE C.E. 4. 93	2		MORSE TIPO / VICES TYPE DSPE. 81	25
	CUBI TIPO / CUBE TYPE C.E. 8. 93	3		MORSE TIPO / VICES TYPE PSPE. 81	26
	CUBI TIPO / CUBE TYPE C.I. 94	4		PROLUNGHE / EXTENSIONS SPE. 81	27
	MORSE TIPO / VICES TYPE E. 03	5		COMPONENTI / COMPONENT PARTS SPE. 81	28
	COMPONENTI / COMPONENT PARTS E. 03	7		MORSE TIPO / VICES TYPE M.I.PA.95	31
	MORSE TIPO / VICES TYPE E.99	9		MORSE TIPO / VICES TYPE GP 76	32
	MORSE TIPO / VICES TYPE EG.99	11		MORSE TIPO / VICES TYPE AC. - PIA. 83	33
	MORSE TIPO / VICES TYPE OE.99	12		COMPONENTI / COMPONENT PARTS AC-PIA. 83	34
	COMPONENTI / COMPONENT PARTS E. 99	13		MORSE TIPO / VICES TYPE GM. 75 - PIG. 83	35
	MORSE TIPO / VICES TYPE SP. 81	15		COMPONENTI / COMPONENT PARTS GM. 75-PIG 83	36
	MORSE TIPO / VICES TYPE DSP. 81	17		MORSE TIPO / VICES TYPE PR. 79	37
	MORSE TIPO / VICES TYPE PSP. 81	18		MANDRINO M.T. 88	38
	PROLUNGHE / EXTENTIONS SP. 81	19		PARALLELE PER MORSE / PAALLEL BARS FOR VICES ...	39
	COMPONENTI / COMPONENT PARTS SP. 81	20		MOLTIPLICATORE ARIA OLIO	40
	MORSE TIPO / VICES TYPE SPE. 81	23			



CUBI TIPO / CUBE TYPE C.E. 4. 93



TIPO / TYPE C.E. 4. 93

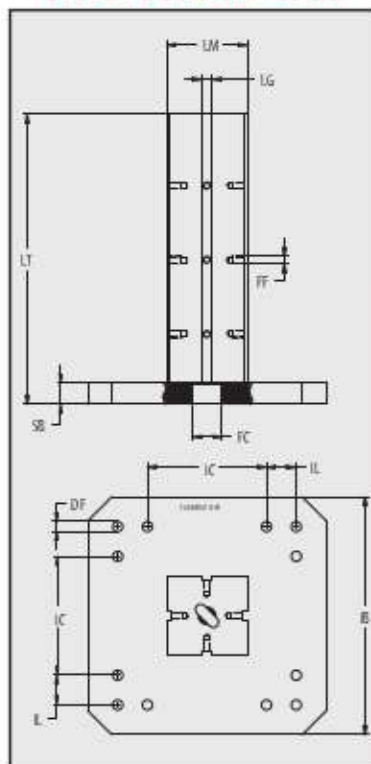

MOD	100	125	150
DF	∅17	∅17	∅17
FC	∅50	∅50	∅50
FF	M10	M12	M12
IC	150	200	250
IL	50	50	50
IB	350	400	500
LG	14	16	16
LM	110	135	160
LT	384	488	600
SB	32	36	38
Peso Kg.	61	106	183

TIPO / TYPE C.E. 4. 93 ED99

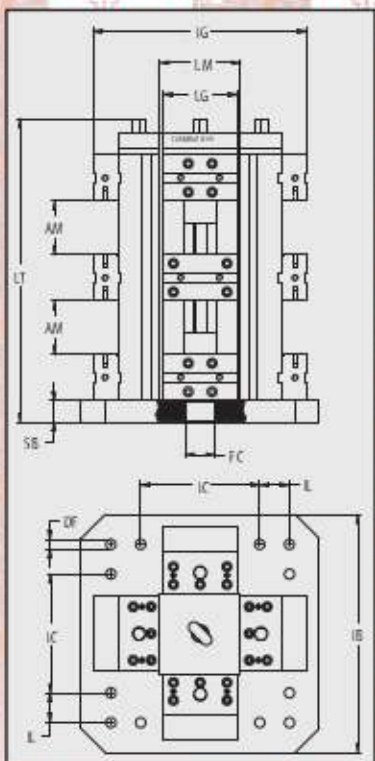

MOD	100	125	150
AM	70	90	145
DF	∅17	∅17	∅17
FC	∅50	∅50	∅50
IC	150	200	250
IL	50	50	50
IB	350	400	500
IG	296	359	424
LG	99	124	149
LM	110	135	160
LT	406,5	510,5	622,5
SB	32	36	38
Peso Kg.	144	330	383

TIPO / TYPE C.E. 4. 93 ES99

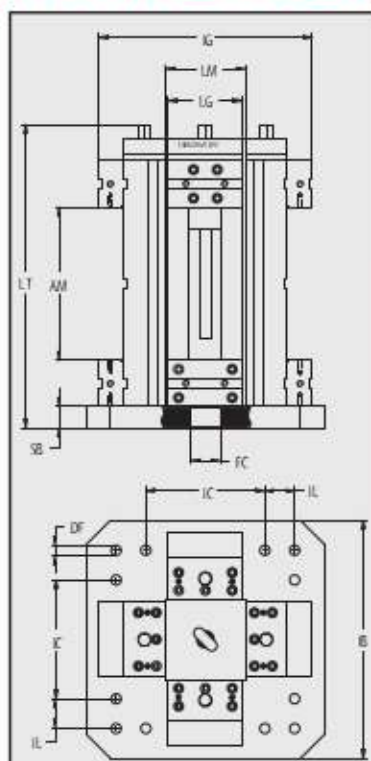

MOD	100	125	150
AM	198	258	368
DF	∅17	∅17	∅17
FC	∅50	∅50	∅50
IC	150	200	250
IL	50	50	50
IB	350	400	500
IG	296	359	424
LG	99	124	149
LM	110	135	160
LT	406,5	510,5	622,5
SB	32	36	38
Peso Kg.	138	318	366

4

 Il cubo tipo C.E.4. 93 la soluzione ideale che la Carminati ha progettato per l'utilizzo contemporaneo di quattro morse in verticale della serie Europa 99. Compatto e ben dimensionato, assicura la massima rigidità per sfruttare al meglio la potenza del C.N. Costruito in acciaio stabilizzato e rettificato con tolleranze centesimali, offre la massima precisione.



The cube type C.E.4. 93 is the ideal solution projected by CARMINATI for using contemporaneously 4 vices of the series Europe 99 vertically. Dimensional and compact, assure maximum rigidity to exploit at best the power of C.N. Built in stabilized steel, rectified with centesimal tolerance further max precision.

CUBI TIPO / CUBE TYPE C.E. 8. 93



TIPO / TYPE C.E. 8. 93

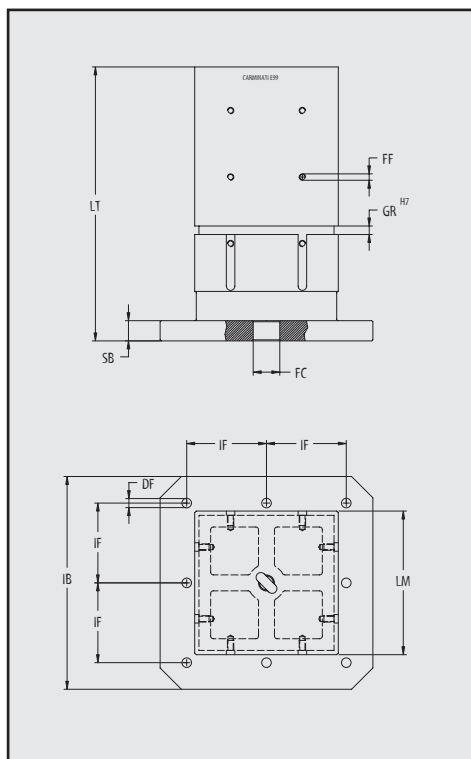

MOD	100	125	150
DF	±17	±17	±17
FC	±50	±50	±50
FF	M10	M12	M12
GR	14	16	16
IF	150	150	200
IB	400	400	500
LM	220	270	320
LT	446	515	631
SB	34	38	42
PesoKg.	124	193	224

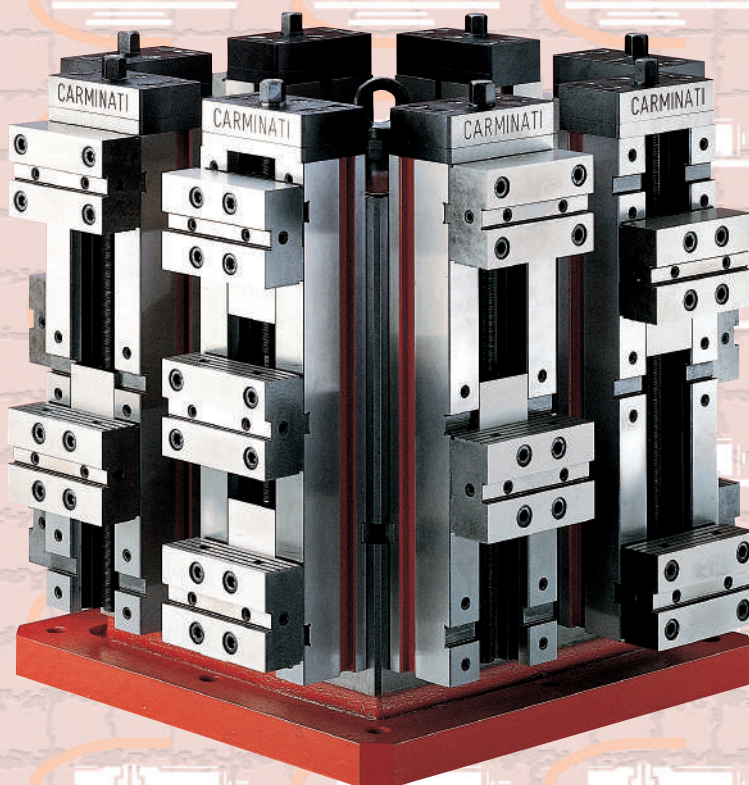

TIPO / TYPE C.E. 8. 93 ES99

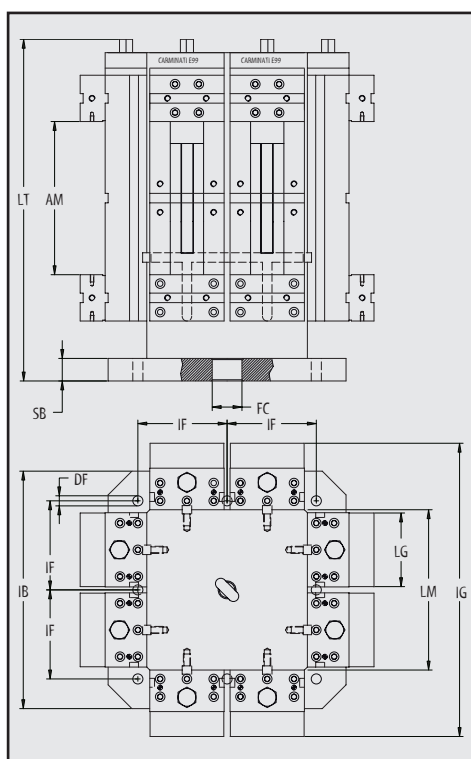

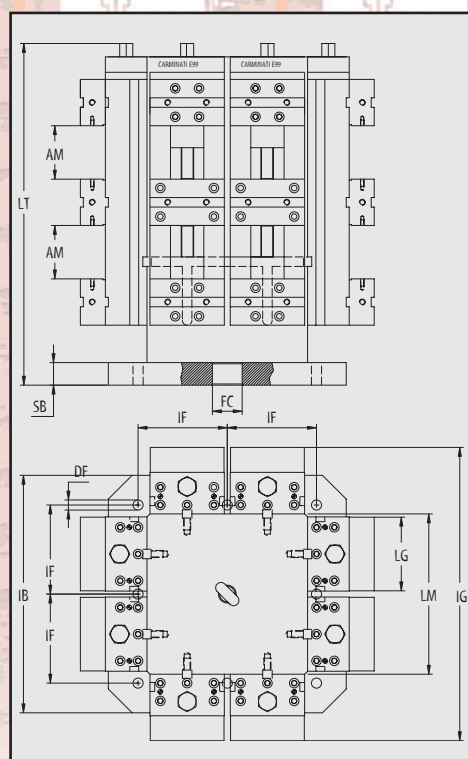

MOD	100	125	150
AM	198	258	368
DF	±17	±17	±17
FC	±50	±50	±50
IF	150	150	200
IB	400	400	500
IG	406	494	584
LG	99	124	149
LM	220	270	320
LT	469,5	575,5	689,5
SB	34	38	42
PesoKg.	270	475	718

TIPO / TYPE C.E. 8. 93 ED99



MOD	100	125	150
AM	70	90	145
DF	±17	±17	±17
FC	±50	±50	±50
IF	150	150	200
IB	400	400	500
IG	406	494	584
LG	99	124	149
LM	220	270	320
LT	469,5	575,5	689,5
SB	34	38	42
PesoKg.	282	499	752

 Il cubo tipo C.E.8. 93 l'attrezzo appropriato per utilizzare contemporaneamente morse in verticale della serie Europa 99. E la soluzione ideale per ridurre i tempi di produzione sul C.N. avendo la possibilit di aumentare la qualita di pezzi in lavorazione. Costruito in ghisa meccanica G30 stabilizzata, offre la massima garanzia. Rettificato sui piani di appoggio assicura tolleranze centesimali.

 The cube type C.E.8. 93 is the appropriate tool to use contemporaneously vices from the series Europa 99 in vertical. It is the ideal solution to reduce the production time on C.N. having the possibility to increase the quantity of workpieces. Built in cast iron mechanics G 30 stabilized, offer max. guaranty, retified on supportface, assure centesimal tolerance.

CUBI TIPO / CUBE TYPE C.I. 94



TIPO / TYPE C.I. 94

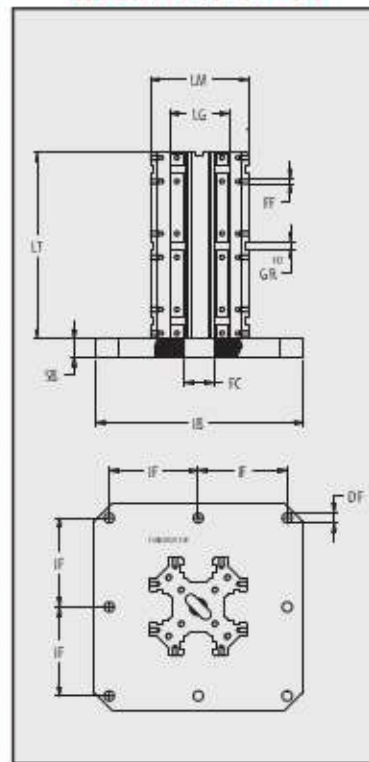

MOD	100	125	150
DF	∅17	∅17	∅17
FC	∅50	∅50	∅50
FF	M8	M10	M12
GR	12	16	16
IB	350	400	500
IF	150	150	200
LG	99	124	149
LM	165	190	240
LT	314	414	524
SB	32	36	38
Peso Kg.	69	117	225

TIPO / TYPE C.I. 94 ED99

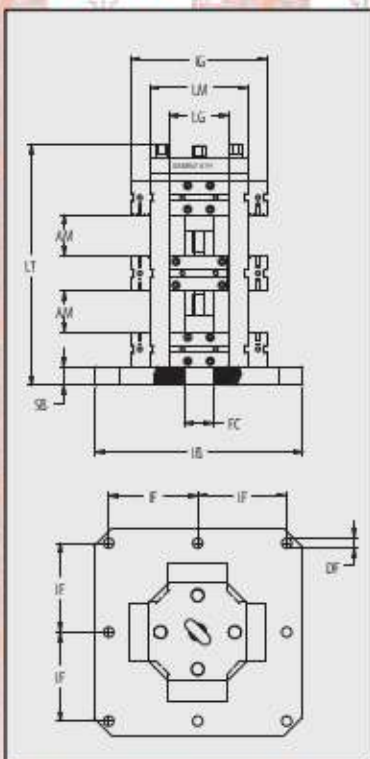

MOD	100	125	150
AM	70	90	145
DF	∅17	∅17	∅17
FC	∅50	∅50	∅50
IF	150	150	200
IB	350	400	500
IG	231	274	344
LG	99	124	149
LM	165	190	240
LT	406,5	511,5	624
SB	32	36	38
Peso Kg.	105	237	315

TIPO / TYPE C.I. 94 ES99

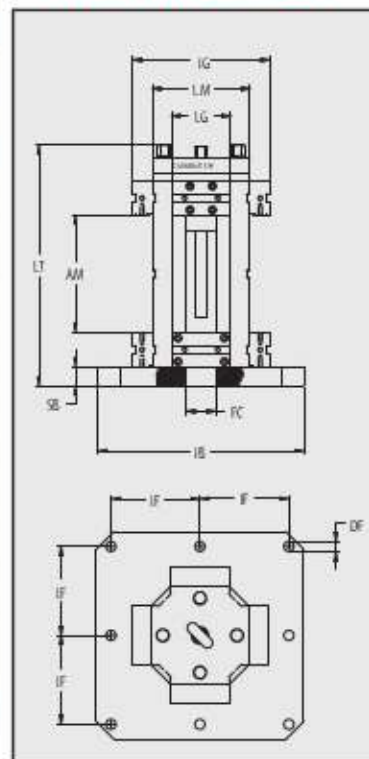

MOD	100	125	150
AM	198	258	368
DF	∅17	∅17	∅17
FC	∅50	∅50	∅50
IF	150	150	200
IB	350	400	500
IG	231	274	344
LG	99	124	149
LM	165	190	240
LT	406,5	511,5	624
SB	32	36	38
Peso Kg.	99	225	298

6

 Il cubo tipo C.I. 94 è l'attrezzatura più completa e versatile per bloccaggi di precisione in verticale. Può essere assemblato con svariate soluzioni di bloccaggio come la serie Europa 99 con la quale è compatibile. Costruito interamente in acciaio al cromo nichel, temprato a 58 HRC, rettificato con tolleranze centesimali, assicura una precisione elevata, massima rigidità e durata nel tempo pressoché illimitata.



The integral cube type C.I. 94 is the most complete and versatile tool for precisely blocking in vertical. Can be assembled with various blocking solutions, as the series Europa 99, with which is compatible. Entirely built in chromium nickel steel, hardened in 58 HRC, rectified with centesimal tolerance, assure high precision, max rigidity, unlimited duration.

MORSE TIPO / VICES TYPE E. 03



TIPO / TYPE ED.03



TIPO / TYPE ES.03



TIPO / TYPE ET.03

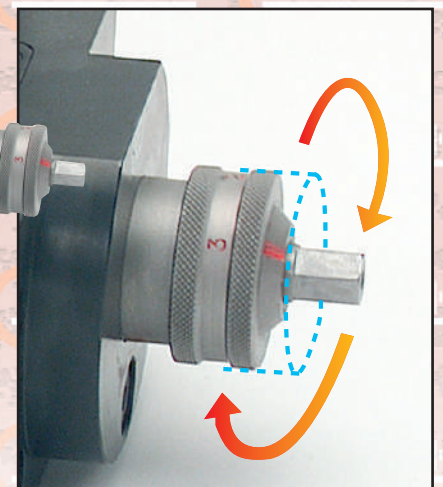



MORSE TIPO / VICES TYPE E. 03

TIPO / TYPE ED. 03

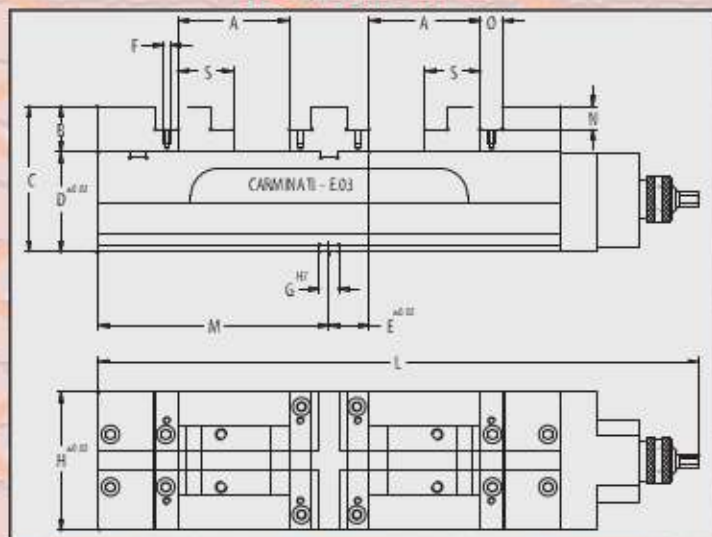

MOD	A	B	C	D	E	F	G	H	L	M	N	O	S	Peso Kg.
100	80	33	109	76	29	M5	14	100	428	167	16.5	16.5	40	24
125	96	42	129	87	39	M6	16	125	518	213	22	24	48	41
150	145	52	148	96	39	M6	16	150	624	262	27	25	48	68

TIPO / TYPE ES.03

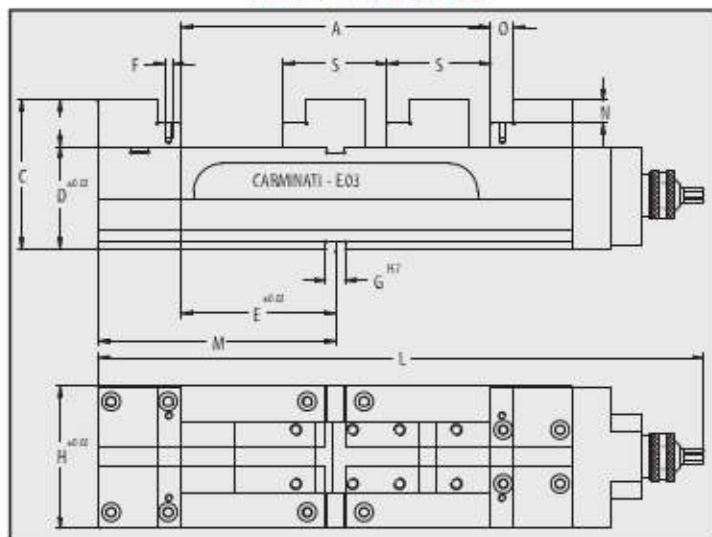

MOD	A	B	C	D	E	F	G	H	L	M	N	O	S	Peso Kg.
100	218	33	109	76	109	M5	14	100	421	167	16.5	16.5	73	20
125	270	42	129	87	135	M6	16	125	521	213	22	24	90	38
150	368	52	148	96	184	M6	16	150	629	262	27	25	92	63

TIPO / TYPE ET.03

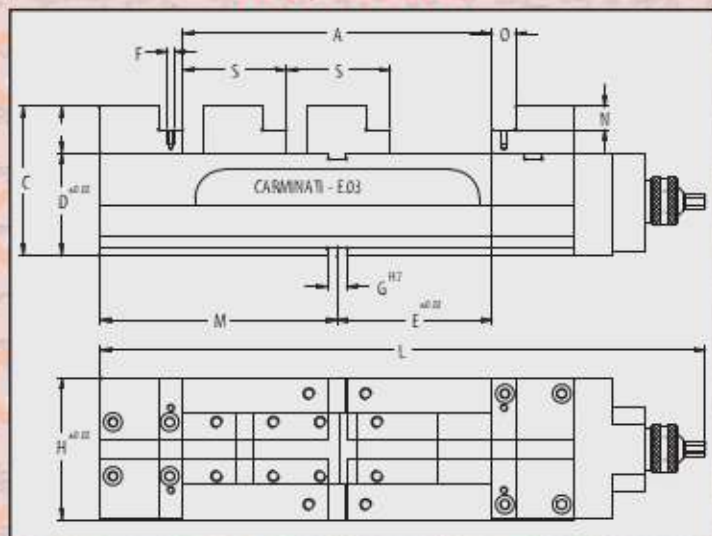

MOD	A	B	C	D	E	F	G	H	L	M	N	O	S	Peso Kg.
100	218	33	109	76	109	M5	14	100	419	167	16.5	16.5	73	20
125	270	42	129	87	135	M6	16	125	501	213	22	24	90	38
150	368	52	148	96	184	M6	16	150	611	262	27	25	92	63

 Il tipo Europa 03 una morsa componibile ad altissima precisione con bloccaggio meccanico-meccanico e copertura della vite di manovra pu essere assemblata in tre diverse soluzioni a secondo delle esigenze di bloccaggio: TIPO ED03 DOPPIA MORSA AUTOBLOCCANTE con possibilit di chiudere i due pezzi contemporaneamente con tolleranza fino a 2mm. - TIPO ES03 MORSA SINGOLA CON BLOCCAGGIO IN SPINTA - TIPO ET03 MORSA SINGOLA CON BLOCCAGGIO IN TIRO. Con la copertura della vite e l utilizzo di materiali al cromo nichel temprati a 58 HRC si assicura una durata pressoché illimitata. Rettificata su tutti i piani pu essere utilizzata in piano o in squadra con tolleranza $\pm 0,02$. Il bloccaggio avviene per mezzo di un moltiplicatore meccanico-meccanico e di un selettore di forza per avere sempre il controllo della spinta. Con l utilizzo delle apposite ganasce a gradini si pu posizionare il pezzo in tre altezze diverse evitando l utilizzo delle parallele.

FORZA DI BLOCCAGGIO:
 MOD. 100 CON KG./F 2000
 MOD. 125 CON KG./F 3000
 MOD. 150 CON KG./F 4000

 The Europa 03 type is a high precision, modular vice. It has a mechanical-mechanical locking facility, and a covered manoeuvring screw. It can be assembled in three different solutions according to locking requirements: TYPE ED03: DOUBLE SELF-LOCKING VICE with facility for closing the two pieces simultaneously, with tolerance up to 2mm.

TYPE ES03: SINGLE VICE WITH THRUST-LOCKING
 TYPE ET03: SINGLE VICE WITH PULL-LOCKING.

The covered spindle screw and use of chromium-nickel materials hardened to 58 HRC, assure almost unlimited long-life. The vice, ground on all surfaces, can be used on-plane or squared with a tolerance of $\pm 0,02$. Locking is by a mechanical-mechanical multiplier and a force selector to ensure constant thrust control.

By using the stepped jaws, you can position the piece at three different heights, thus avoiding use of parallels.

LOCKING FORCE
 MOD. 100 WITH KG./F 2000
 MOD. 125 WITH KG./F 3000
 MOD. 150 WITH KG./F 4000

COMPONENTI / COMPONENT PARTS E. 03



CORPO MORSA/VICE BODY E03

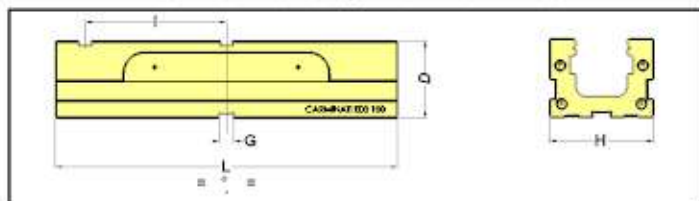

MOD	D	G	H	I	L
100	76	14	100	138	334
125	87	16	125	174	426
150	96	16	150	223	524

CORPO FISSO 2 GRADINI/FIXED BODY WITH 2 STEPS E03

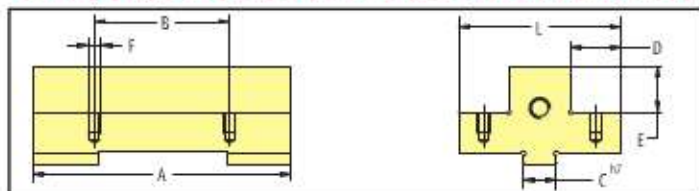

MOD	A	B	C	D	E	F	L	S
100	99	56	12	16.5	16.5	M5	58	33
125	124	65	16	24	22	M6	78	42
150	149	88	16	25	27	M6	78	52

CORPO FISSO 1 GRADINO/FIXED BODY WITH 1 STEPS E03

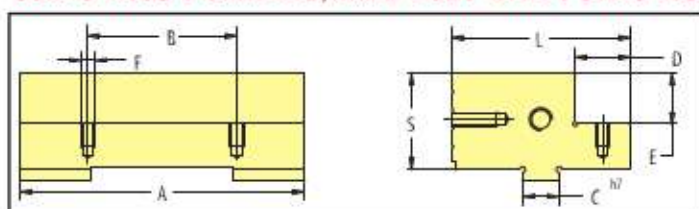

MOD	A	B	C	D	E	F	L	S
100	99	56	12	16.5	16.5	M5	58	33
125	124	65	16	24	22	M6	78	42
150	149	88	16	25	27	M6	78	52

CARRELLO 1 GRADINO/TROLLEY, 1 STEP E03

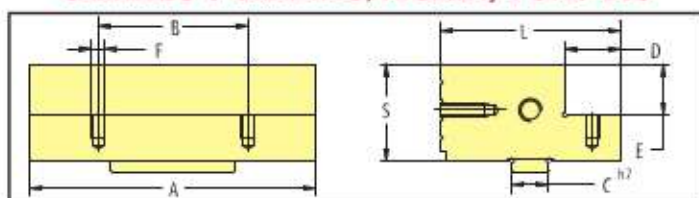

MOD	A	B	C	D	E	F	L	S
100	99	56	12	16.5	16.5	M5	58	33
125	124	65	16	24	22	M6	78	42
150	149	88	16	25	27	M6	78	52

GUIDA CARRO/TROLLEY GUIDE ED03

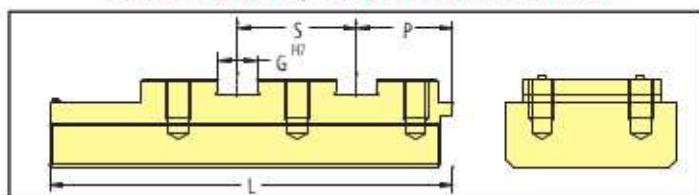

MOD	G	L	P	S
100	14	125	29	40
125	16	163	39	48
150	16	210	39	96

GUIDA CARRO/TROLLEY GUIDE ES-ET03

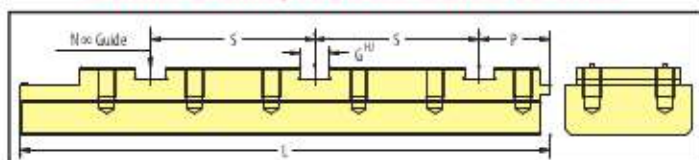

MOD	G	L	N GUIDE	P	S
100	12	238	3	29	73
125	16	290.5	3	39	90
150	16	368	4	39	92

STAFFE MORSE/BRACKETS VICE E03

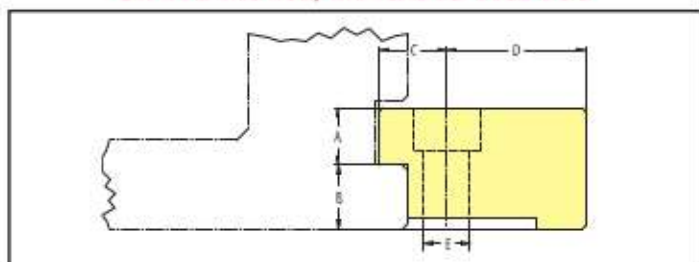

MOD	A	B	C	D	E
100	16	18	19	39	xM12
125	15	24	22	36	xM12
150	15	24	22	36	xM12



COMPONENTI / COMPONENT PARTS E. 03

GUIDA RIFERIMENTO/REFERENCE GUIDE E03

MOD	A	C	D	H	L	F	B
100	14	6	6	12	25	xM6	A richista
125	16	6	6	12	25	xM6	A richista
150	16	6	6	12	25	xM6	A richista

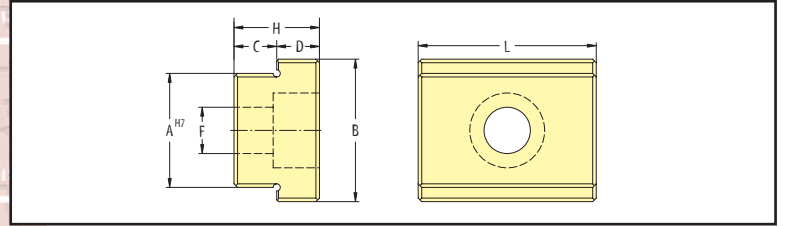

GRUPPO VITE/SCREW UNIT ED03

MOD	L	F	CORSA VITE
100	370	M24X3	40-40
125	425,5	M27X3	48-48
150	486,5	M30X3	48-48

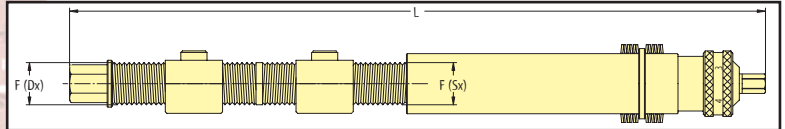

GRUPPO VITE/SCREW UNIT ET03

MOD	L	F	CORSA VITE
100	338	M24X3	73
125	370,5	M27X3	90
150	456	M30X3	92

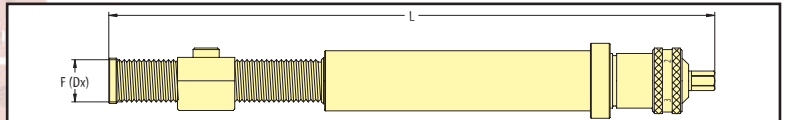

GRUPPO VITE/SCREW UNIT ES03

MOD	L	F	CORSA VITE
100	324	M24X3	73
125	380,5	M27X3	90
150	404	M30X3	92

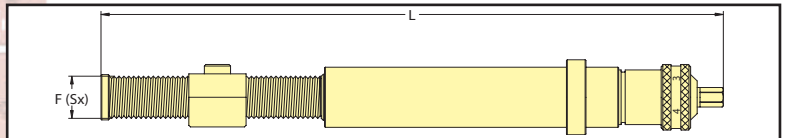

COPERCHIO GUIDA VITE/SCREW GUIDE COVER ED03

MOD	H	L	S
100	75	99	49
125	86	124	58
150	96	149	63

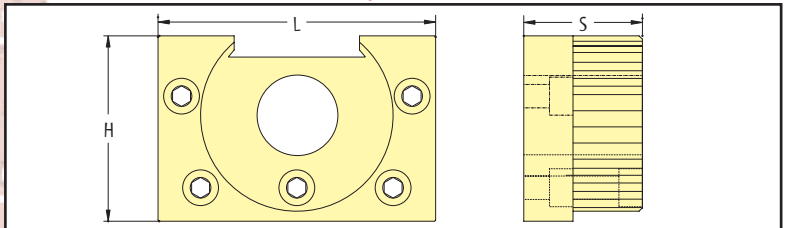

COPERCHIO GUIDA VITE/SCREW GUIDE COVER ET03

MOD	H	L	S
100	75	99	38
125	86	124	38
150	96	149	49

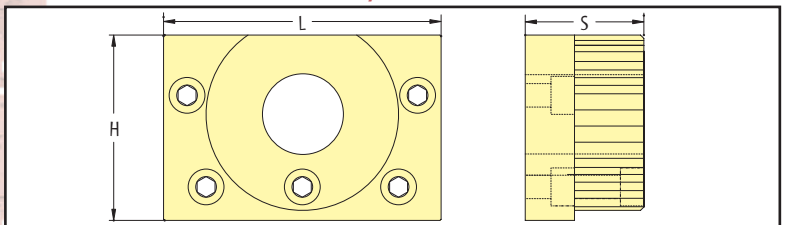

COPERCHIO GUIDA VITE/SCREW GUIDE COVER ES03

MOD	H	L	S
100	75	99	49
125	86	124	58
150	96	149	63

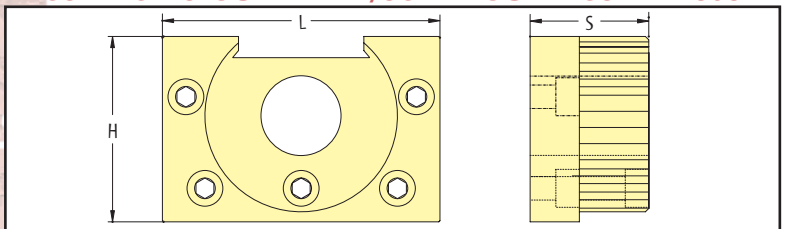

GANASCIA A GRADINO/STEPPED JAW E03

MOD	A	B	C	D	F	G	H	L	M
100	99	58	16.5	16.5	±5.3	3	4	3	6
125	124	66	22	24	±6.5	4	5	4	8
150	149	85	27	25	±6.5	4	5	4	8

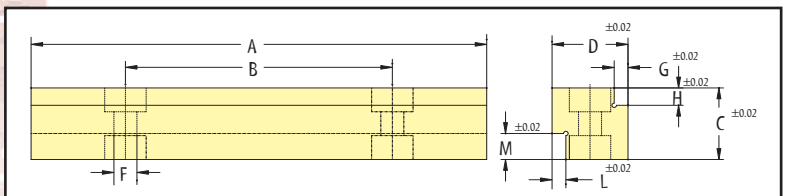

MORSE TIPO / VICES TYPE E.99



TIPO / TYPE ED.99

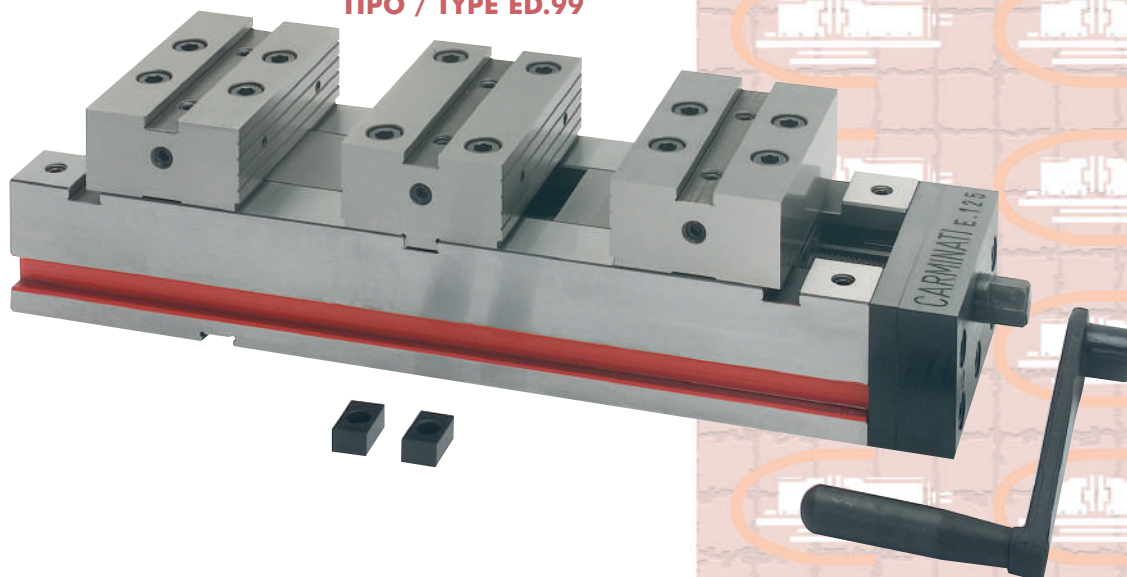

TIPO / TYPE ES/T 99

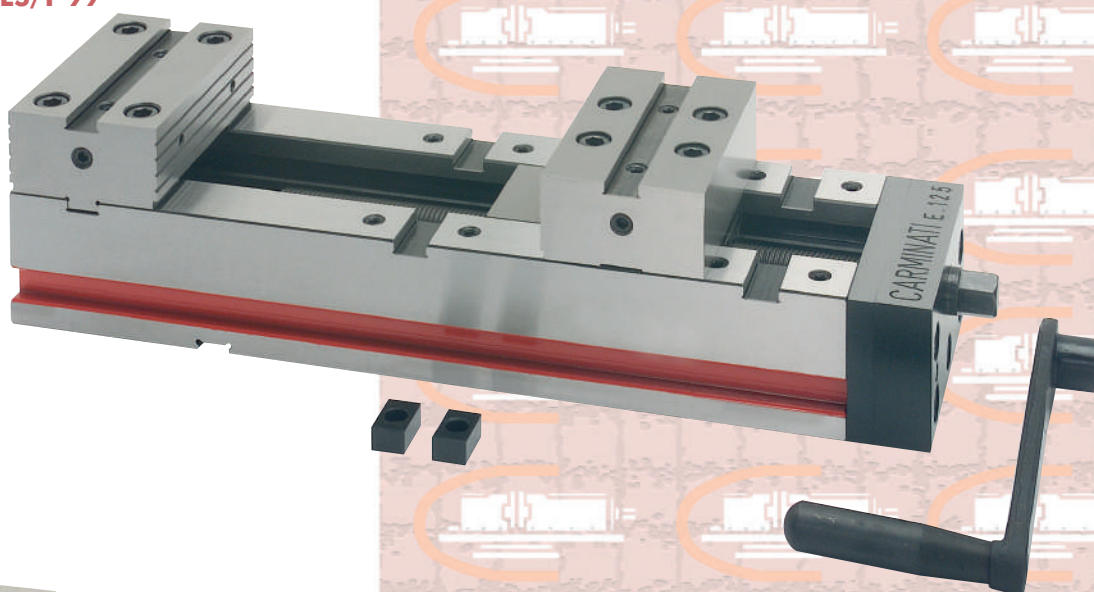

TIPO / TYPE EA.99

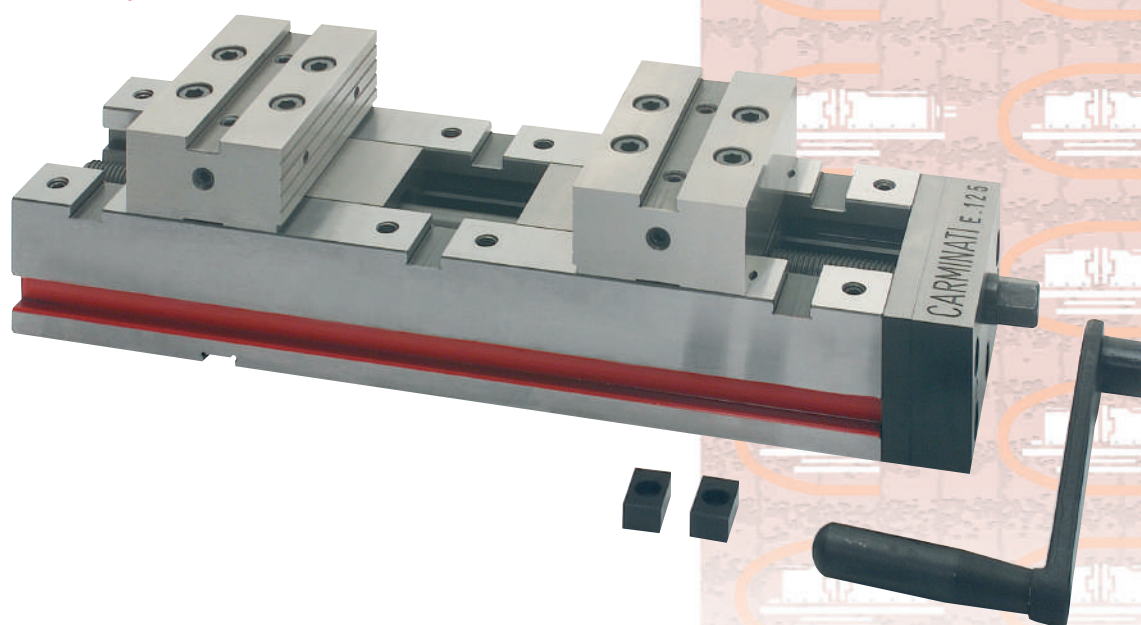



MORSE TIPO / VICES TYPE E.99

TIPO / TYPE ED.99

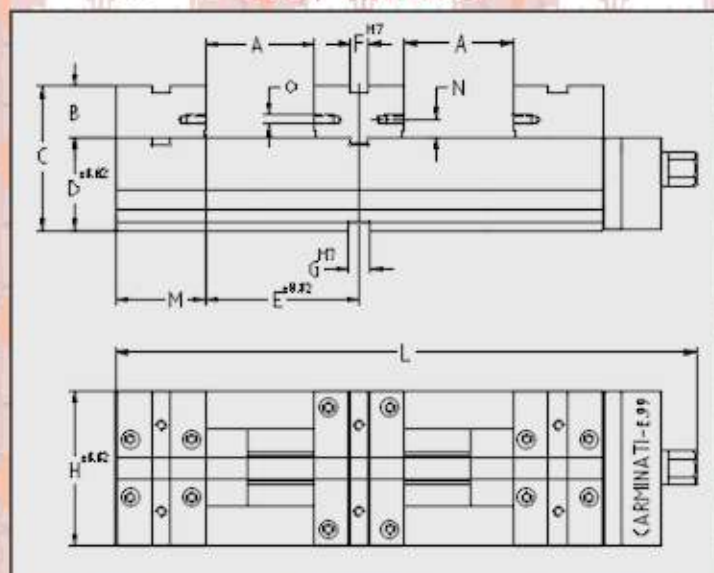

MOD	A	B	C	D	E	F	G	H	L	M	N	O	Peso Kg.
100	70	33	93	60	99	12	14	100	383,5	58	12	M6	20
125	96	42	112	70	129	16	16	125	483,5	78	22	M6	38
150	145	52	132	80	184	16	16	150	590,5	78	22	M8	61

TIPO / TYPE ES/T 99

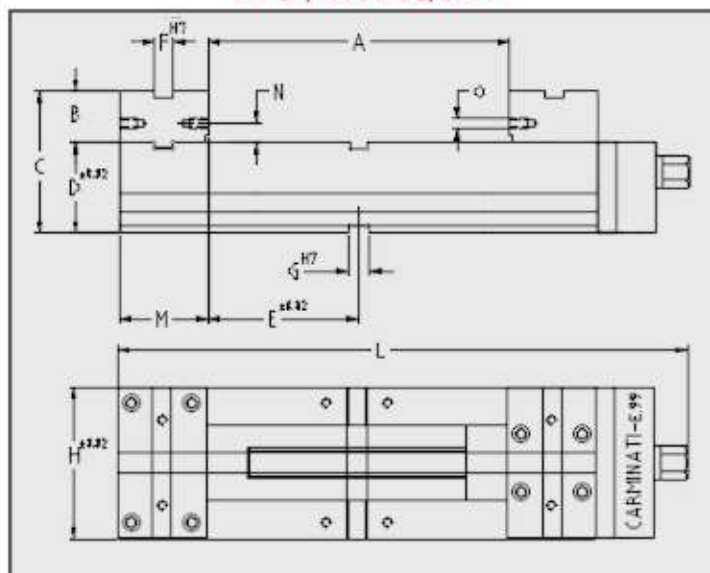

MOD	A	B	C	D	E	F	G	H	L	M	N	O	Peso Kg.
100	198	33	93	60	99	12	14	100	383,5	58	12	M6	18,5
125	258	42	112	70	129	16	16	125	483,5	78	22	M6	35
150	368	52	132	80	184	16	16	150	590,5	78	22	M8	56

TIPO / TYPE EA.99

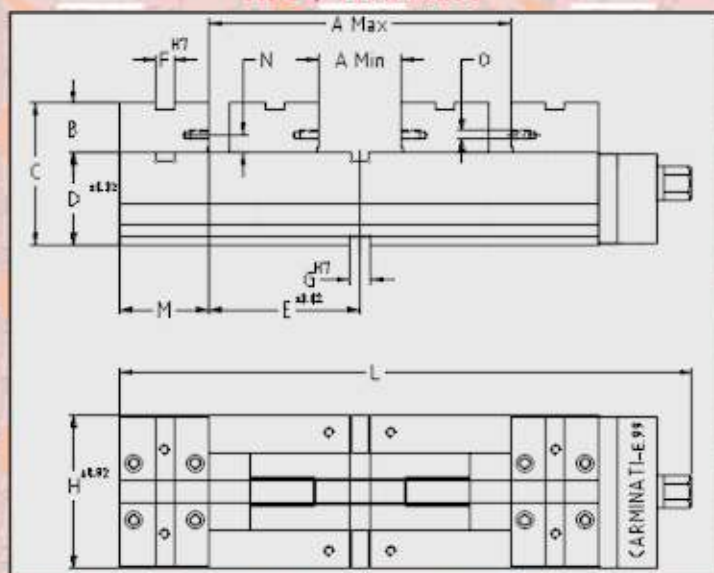

MOD	A _{max}	A _{min}	B	C	D	E	F	G	H	L	M	N	O	Peso Kg.
100	198	54	33	93	60	99	12	14	100	381,5	58	12	M6	18,5
125	258	74	42	112	70	129	16	16	125	481,5	78	22	M6	35
150	368	74	52	132	80	184	16	16	150	588	78	22	M8	56

La serie Europa 99 la morsa componibile di altissima precisione con svariate possibili di utilizzo. Pu essere assemblata a piacimento con infinite soluzioni di bloccaggio:

- TIPO ED. 99, doppia morsa a chiusura autobloccante
- TIPO EA. 99, morsa a chiusura autocentrante
- TIPO ES. 99, morsa con bloccaggio a spinta
- TIPO ET. 99, morsa con bloccaggio in tiro. Sulle parti mobili e fisse stata preparata una guida di posizionamento per il montaggio di eventuali ganasce speciali. Questa serie pu essere utilizzata in piano o in fianco. Costruita interamente in acciaio al cromo nichel, temprata a 58 HRC e rettificata con tolleranze centesimali, assicura una durata nel tempo pressoch illimitata.

The series EUROPA 99 is a composable high precision vice with varied utilisations; can be used as you like with infinite blocking solutions:

- type E.D.M.A. 99 - autocentred self-locking doubled vice
 - type E.M.A. 99 - autocentred locking vice
 - type E.M.S. 99 - vice with draught or thrust blocking.
- On the mobile and fixed parts there is a position guide for eventually assembling of special jaws. This range can be used on level ground or on side. Entirely built in chromium nickel steel, hardened in 58 HRC and retified with centesimal tolerance, to secure unlimited duration.

MORSE TIPO / VICES TYPE EG.99



TIPO / TYPE EGS/T.99

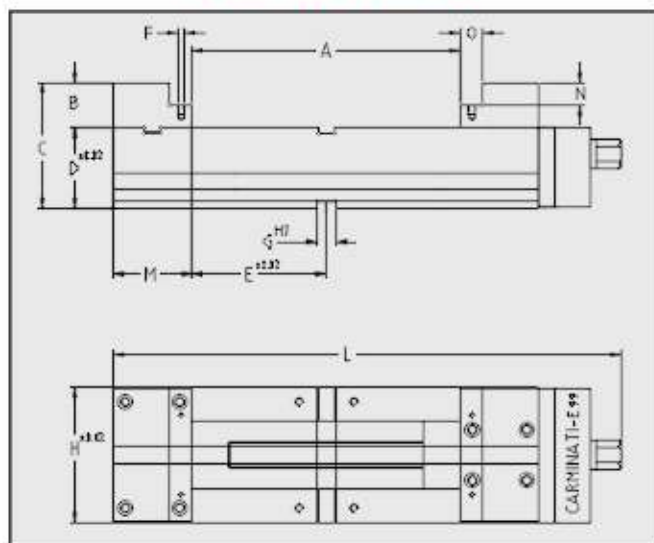

MOD	A	B	C	D	E	F	G	H	L	M	N	O	Peso Kg.
100	198	33	93	60	99	M5	14	100	383,5	58	16,5	16,5	18,5
125	258	42	112	70	129	M6	16	125	483,5	78	22	24	35
150	368	52	132	80	184	M6	16	150	590,5	78	27	25	56

TIPO / TYPE EGD.99

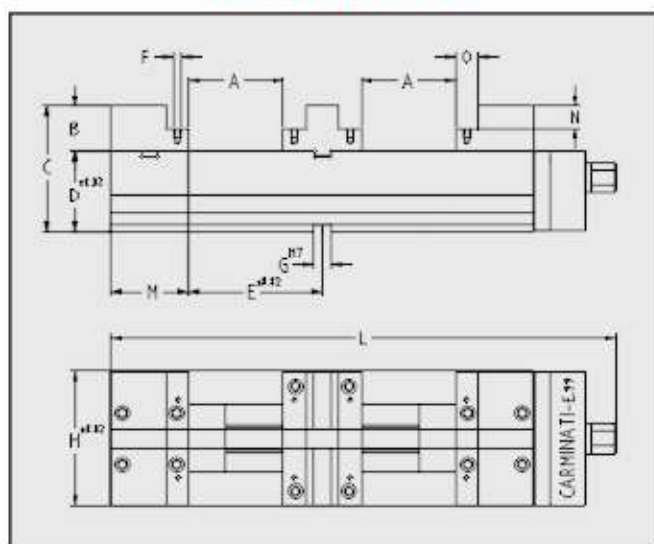

MOD	A	B	C	D	E	F	G	H	L	M	N	O	Peso Kg.
100	70	33	93	60	99	M5	14	100	383,5	58	16,5	16,5	20
125	90	42	112	70	129	M6	16	125	483,5	78	22	24	38
150	145	52	132	80	184	M6	16	150	590,5	78	27	25	61

TIPO / TYPE EGA.99

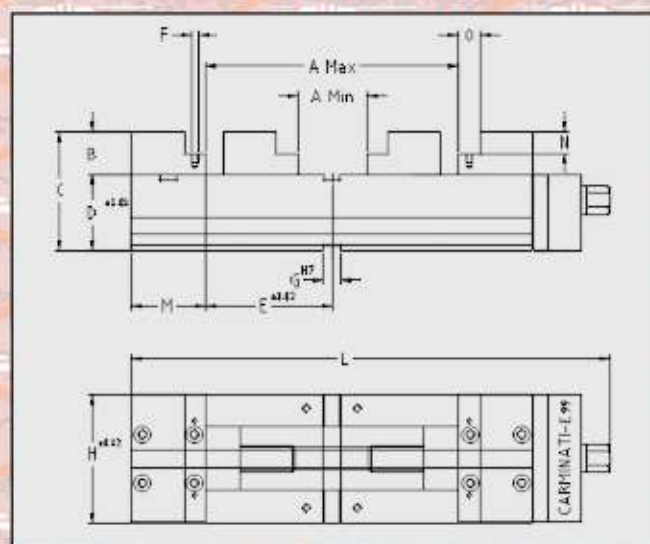

MO	Amax	Amin	B	C	D	E	F	G	H	L	M	N	O	Peso Kg.
100	198	54	33	93	60	99	M5	14	100	381,5	58	16,5	16,5	18,5
125	258	74	42	112	70	129	M6	16	125	481,5	78	22	24	35
150	368	74	52	132	80	184	M6	16	150	588	78	27	25	56

 Sostituendo alle morse TIPO EUROPA E 99 corpi fissi e carri diventano EG. 99. Con l'utilizzo delle apposite ganasce a gradini si pu' posizionare il pezzo in tre diverse altezze, evitando l'utilizzo delle parallele. Vengono costruite per tutti i modelli Europa 99.

 By replacing the fixed bodies and carriages on the TYPE EUROPA E 99 vices, they become EG 99. By using the stepped jaws, the piece can be positioned at three different heights, thus avoiding the use of parallels. They are built for all Europa 90 models.

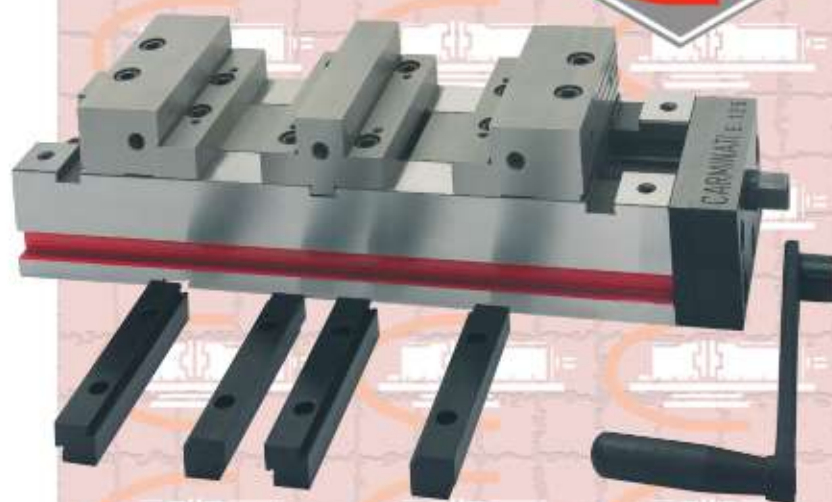



MORSE TIPO / VICES TYPE OE.99



TIPO / TYPE OED.99

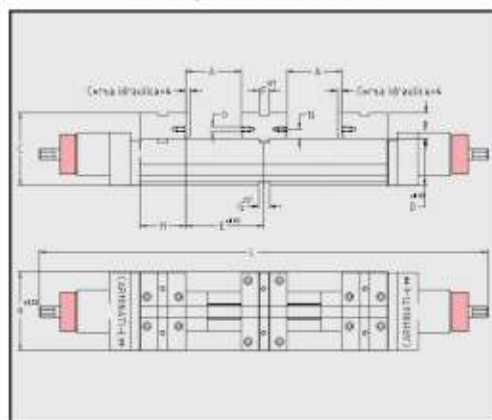

TIPO / TYPE OES.99

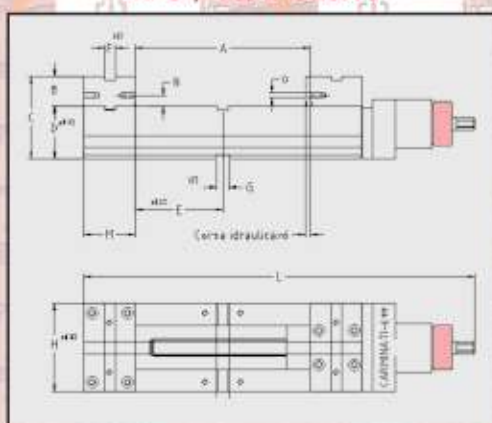

TIPO / TYPE OEGD.99

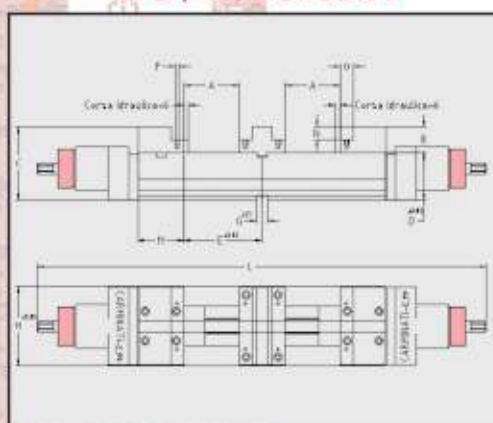

TIPO / TYPE OEGS.99

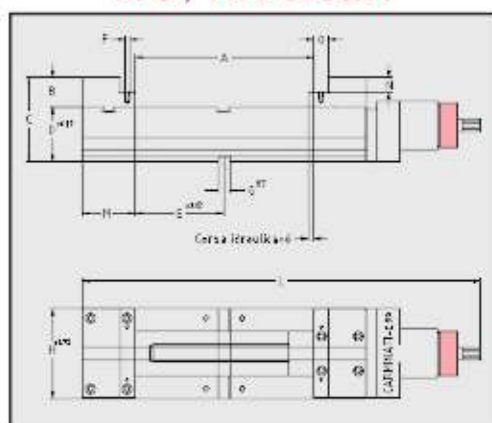

OED.99

MOD	A	B	C	D	E	F	G	H	L	M	N	O	Peso Kg.
100	70	33	93	60	99	12	14	100	558	58	12	M6	24
125	90	42	112	70	129	16	16	125	658	78	22	M6	41
150	145	52	132	80	184	16	16	150	768	78	22	M8	65

OES.99

MOD	A	B	C	D	E	F	G	H	L	M	N	O	Peso Kg.
100	198	33	93	60	99	12	14	100	436	58	12	M6	20.5
125	258	42	112	70	129	16	16	125	536	78	22	M6	36.5
150	368	52	132	80	184	16	16	150	646	78	22	M8	58

OEGD.99

MO	A	B	C	D	E	F	G	H	L	M	N	O	Peso Kg.
100	70	33	93	60	99	M5	14	100	558	58	16.5	16.5	24
125	90	42	112	70	129	M6	16	125	658	78	22	24	41
150	145	52	132	80	184	M6	16	150	768	78	27	25	65

OEGS.99

MOD	A	B	C	D	E	F	G	H	L	M	N	O	Peso Kg.
100	198	33	93	60	99	M5	14	100	436	58	16.5	16.5	20.5
125	258	42	112	70	129	M6	16	125	536	78	22	24	36.5
150	368	52	132	80	184	M6	16	150	646	78	27	25	58

 Per le morse TIPO E99-EG99 previsto un bloccaggio oleopneumatico: sono le morse TIPO OE99-OEG99. Mediante un cilindro idraulico inserito nel coperchio e il moltiplicatore di pressione aria-olio possibile un bloccaggio sicuro senza affaticamento dell'operatore. Il posizionamento del carro avviene mediante la rotazione della vite.

Per il bloccaggio del pezzo sufficiente azionare la valvola del moltiplicatore aria-olio; la corsa oleodinamica di mm 6.

La forza di bloccaggio con 8 bar di Kg./F 1900 per i modelli 100-125 e di Kg./F 3500 per il modello 150.

Il bloccaggio oleodinamico si pu montare sui modelli ED99-ES99-EGD99-EGS99.

 Hydraulic locking is provided for vices TYPE E99-EG99. These vices are known as TYPE OE99-OEG99. Secure locking, without tiring the operator, is obtained by the use of a hydraulic cylinder fitted in the cover and an air-oil pressure multiplier. The carriage is positioned by screw rotation. To lock the piece, just activate the air-oil multiplier valve - the hydraulic stroke is 6 mm.

Locking force at 8 bar for models 100-125: 1900 kg./F

Locking force at 8 bar for model 150: 3500 kg./F The hydraulic

locking system can be installed on models. ED99-ES99-EGD99-EGS99.

COMPONENTI / COMPONENT PARTS E. 99



CORPO BASE/BASIC BODY E. 99

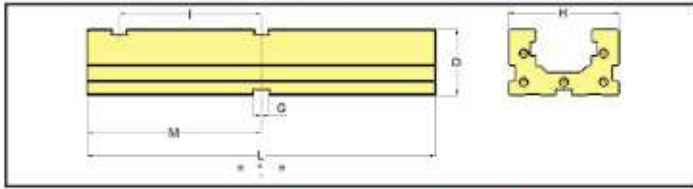

MOD	D	G	H	I	L	M
100	60	14	100	128	314	157
125	70	14	125	168	414	207
150	80	16	150	223	524	262

CORPO FISSO/FIXED BODY E. 99

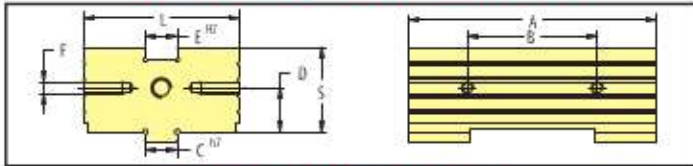

MOD	A	B	C	D	E	F	L	S
100	99	56	12	12	12	M6	58	33
125	124	65	16	22	16	M6	78	42
150	149	88	16	22	16	M8	78	52

CARRELLO/TROLLEY E. 99

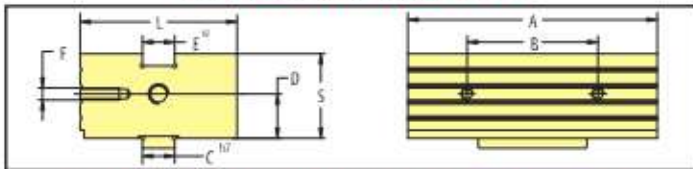

MOD	A	B	C	D	E	F	L	S
100	99	56	12	12	12	M6	58	33
125	124	65	16	22	16	M6	78	42
150	149	88	16	22	16	M8	78	52

CORPO FISSO 1 GRADINO/FIXED BODY WITH 1 STEP E.G. 99

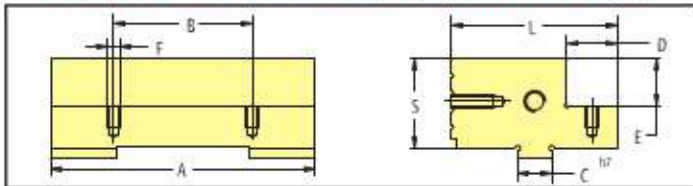

MOD	A	B	C	D	E	F	L	S
100	99	56	12	16.5	16.5	M5	58	33
125	124	65	16	24	22	M6	78	42
150	149	88	16	25	27	M6	78	52

CORPO FISSO 2 GRADINI/FIXED BODY WITH 2 STEPS E.G. 99

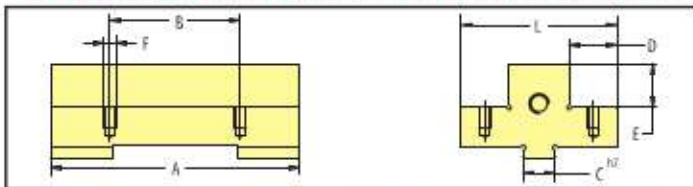

MOD	A	B	C	D	E	F	L	S
100	99	56	12	16.5	16.5	M5	58	33
125	124	65	16	24	22	M6	78	42
150	149	88	16	25	27	M6	78	52

CARRELLO 1 GRADINO/TROLLEY WITH 1 STEP E.G. 99

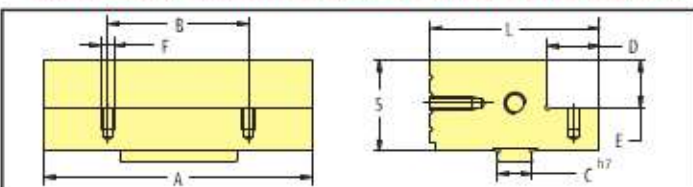

MOD	A	B	C	D	E	F	L	S
100	99	56	12	16.5	16.5	M5	58	33
125	124	65	16	24	22	M6	78	42
150	149	88	16	25	27	M6	78	52

STAFFE MORSE/BRACKETS VICE E. 99

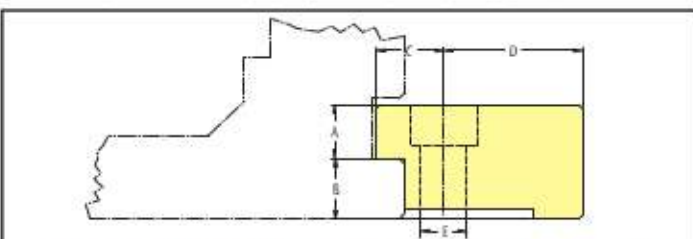

MOD	A	B	C	D	E
100	11.5	13.5	17	23	xM12
125	13	14	18	27	xM12
150	16	18	19	39	xM12

GUIDA RIFERIMENTO/REFERENCE GUIDE E. 99

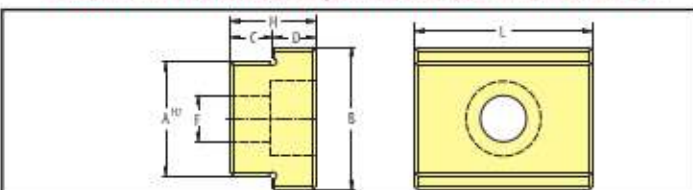

MOD	A	C	D	H	L	F	B
100	14	6	6	12	25	xM6	A richista
125	16	6	6	12	25	xM6	A richista
150	16	6	6	12	25	xM6	A richista



COMPONENTI / COMPONENT PARTS E. 99

GUIDA DEL CARRO/TROLLEY GUIDE E. 99

MOD	G	L	P
100	12	85	29
125	16	115	39
150	16	115	39

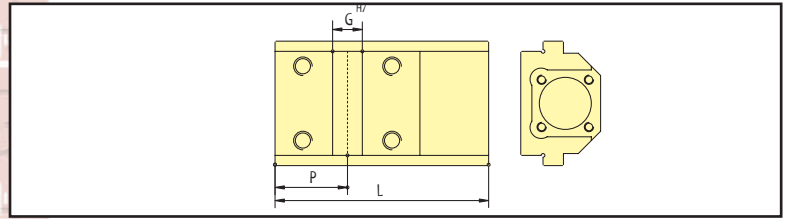

MOD	H	L	S
100	67.5	99	79
125	75.5	124	79
150	96.5	149	74

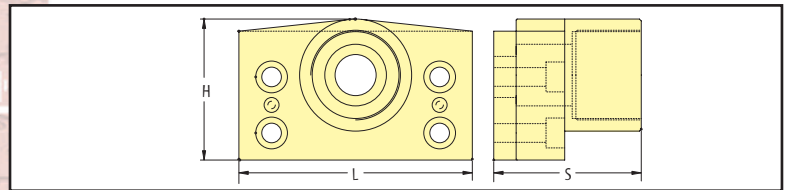

MOD	H	L	S
100	59	99	38
125	69	124	38
150	79	149	38

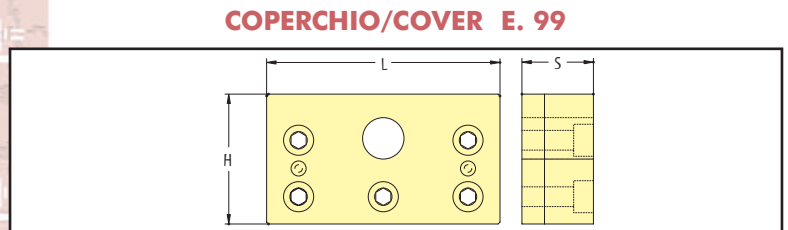

MOD	A	B	C	D	E
100	M48	±24	30	56	1/8
125	M48	±24	30	56	1/8
150	M68	±35	45	58	1/8

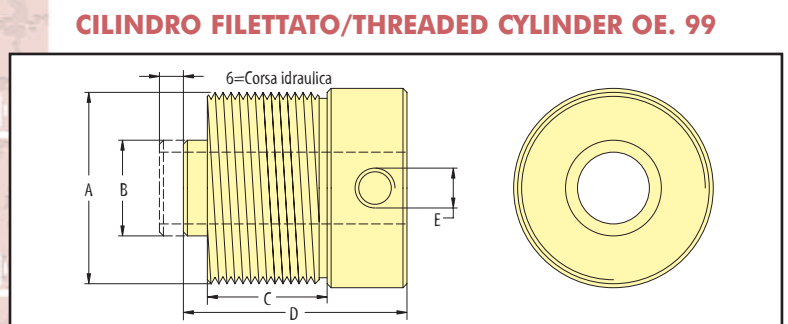

MOD	A	B	C	D	F	G	H	L	M
100	99	58	16.5	16.5	±5.3	3	4	3	6
125	124	66	22	24	±6.5	4	5	4	8
150	149	85	27	25	±6.5	4	5	4	8

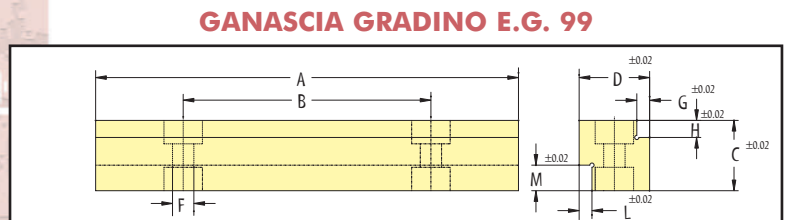

MOD	F	L
100	M20x2.5	297.5
125	M20x2.5	357.5
150	M24x3	495.5

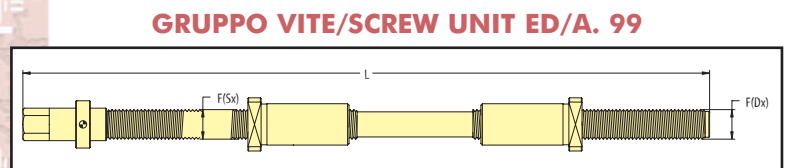

MOD	F	L
100	M20x2.5	297.5
125	M20x2.5	357.5
150	M24x3	495.5

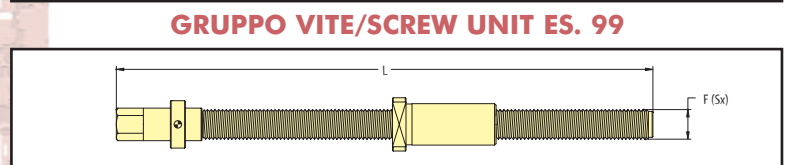

MOD	F	L
100	M20x2.5	374.5
125	M20x2.5	474.5
150	M24x3	584

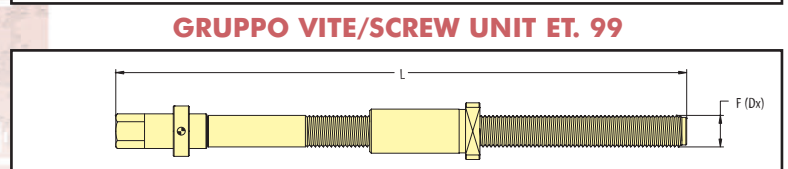



MORSE TIPO / VICES TYPE SP. 81

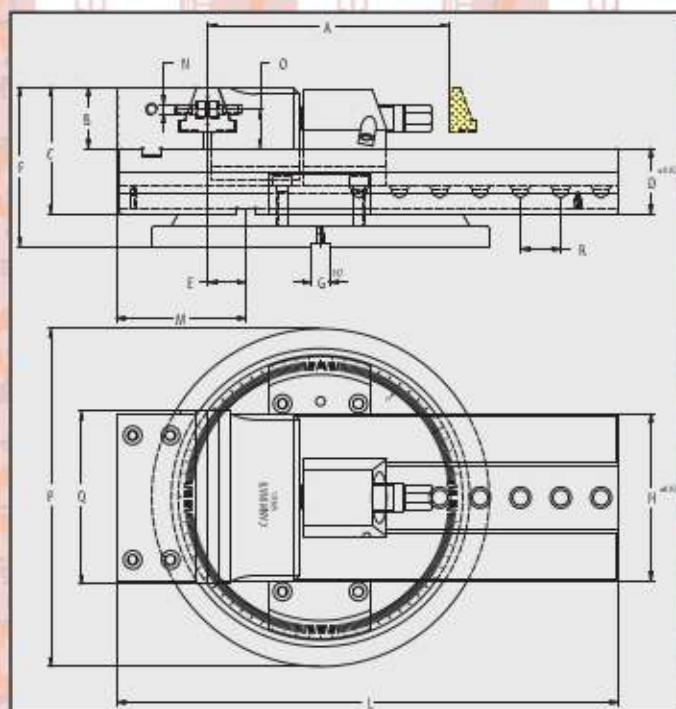

TIPO / TYPE SP. 81

MOD	100	125	150	200
A	120	159	210	320
B	39.5	46	53	67
C	79.5	89	110	134
D	40	43	57	67
E	84,6	99,54	131,04	191,54
F	102.5	116	138	168
G	14	14	16	16
H	95	120	145	195
L	314,5	366	449	613
M	157,25	183	224,5	306,5
N	M6	M6	M8	M8
O	25.5	30	34	43.5
P	205	238	293	343
Q	100	125	150	200
R	20	27	35	40
Peso Kg.	17.6	27.5	49	97



 Le morse tipo SP81 di altissima precisione sono costruite in acciaio di nichel temprato. Rappresentano la punta di diamante della produzione Carminati: con l'impiego dei componenti opzionali possono essere composte in diverse soluzioni per differenti problematiche di bloccaggio.

Caratteristiche principali:

- ganasce discendenti che bloccano in qualsiasi condizione il pezzo sul piano della morsa;
- controllo ritorno delle ganasce;
- grande apertura e rapidità di posizionamento per lavorazioni non di serie.

Sono particolarmente indicate per attrezzisti e stampisti. Rettificate in tutti i particolari che le compongono garantiscono la massima precisione.

Sono prodotte in quattro modelli: 100 - 125 - 150 - 200.

 STEEL PRECISION VICES WITH DESCENDING JAWS TYPE SP81. High precision SP81 vice are made of hardened nickel steel. They are the show-piece of the Carminati production. For holding piece with difficult shapes, the vice is fitted with optional components providing various solutions. Main feature: descending jaws that clamp the piece on the plate under any conditions; - jaw return control; - wide opening and quick positioning for non-standard machining. They are particularly useful for toolmakers and diesinkers. All parts are hardened, which ensures maximum precision. They come in four models: 100 - 125 - 150 - 200.



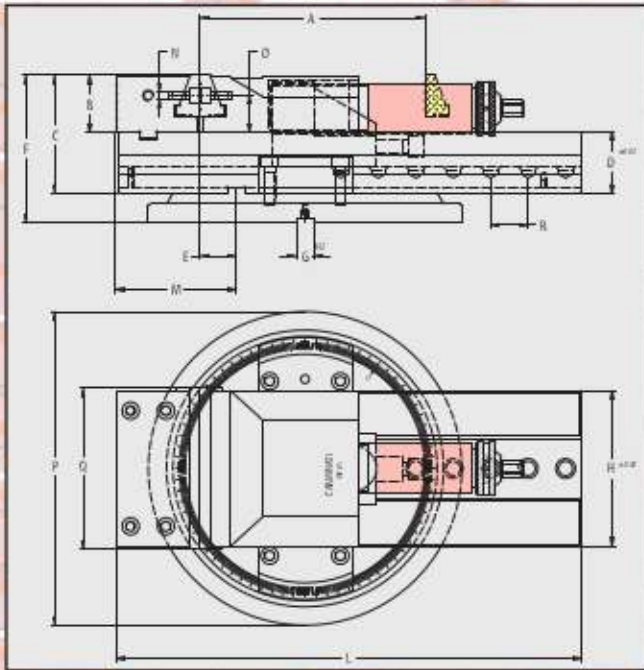

MORSE TIPO / VICES TYPE ISP.-MSP.-OSP. 81

TIPO / TYPE ISP. 81 - MSP 81



MOD	A	B	C	D	E	F	G	H	L	M	N	O	P	Q	R	Peso Kg.
100	120	39,5	79,5	40	84,8	102,5	14	95	314,5	157,25	M6	25,5	205	100	20	17,6
125	159	46	89	43	99,54	116	14	120	366	183	M6	30	238	125	27	27,5
150	210	53	110	57	131,04	138	16	145	449	224,5	M8	34	293	150	35	49
200	320	67	134	67	191,54	168	16	195	613	306,5	M8	43,5	343	200	40	97

 Le morse SP81 con bloccaggio mecano-idraulico si chiamano ISP81; con il bloccaggio mecano-meccanico sono le MSP81. Scegliendo, per mezzo del nonio inciso sulla vite, la spinta necessaria per la lavorazione si ottiene sempre un bloccaggio costante. Sono prodotte in quattro modelli: MOD. 100 Kg/F 2000 - MOD. 125 Kg/F 3000 - MOD. 150 Kg/F 4000 - MOD. 200 Kg/F 5000

 SPARE PARTS81 vices with mechanical-hydraulic locking are known as ISP81. With mechanical-mechanical locking, they are known as MSP81. If, by using the vernier scale cut on the screw, you select the necessary thrust for your work, you will always obtain constant locking. Available in four models: MOD. 100 Kg/F 2000 - MOD. 125 Kg/F 3000 - MOD. 150 Kg/F 4000 - MOD. 200 Kg/F 5000

TIPO / TYPE OSP. 81

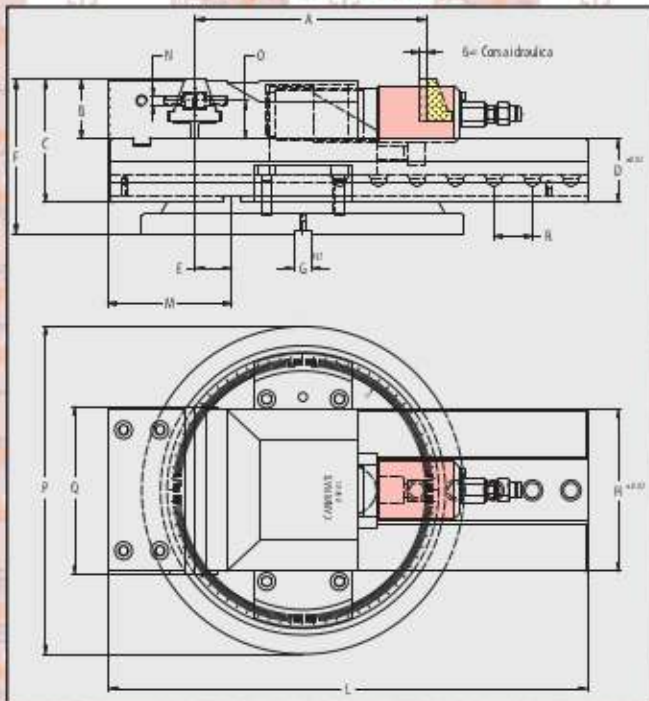

MOD	A	B	C	D	E	F	G	H	L	M	N	O	P	Q	R	Peso Kg.
125	159	46	89	43	99,54	116	14	120	366	183	M6	30	238	125	27	27,5
150	210	53	110	57	131,04	138	16	145	449	224,5	M8	34	293	150	35	49
200	320	67	134	67	191,54	168	16	195	613	306,5	M8	43,5	343	200	40	97

 Le morse SP81 con bloccaggio oleopneumatico si chiamano OSP81. Mediante un cilindro idraulico inserito nella vite ed un moltiplicatore di pressione aria-olio il bloccaggio rapido e sicuro, senza affaticamento dell'operatore. La posizione del carro regolata mediante la rotazione della vite con una semplice chiave. Il bloccaggio del pezzo comandato mediante l'azionamento della valvola sul moltiplicatore aria-olio. Sono ottimali per lavorazioni di serie. La corsa oleodinamica di 6 mm. Sono prodotte in tre modelli: MOD. 125 CON 2500 Kg./F a 8 bar - MOD. 150 CON 4500 Kg./F a 8 bar - MOD. 200 CON 5000 Kg./F a 8 bar

 OSP81 VICES TYPE OSP81
SP81 vices with hydraulic locking from the series OSP81. A hydraulic cylinder inserted in the screw and an air-oil pressure multiplier ensure quick and safe damping, without excessive work for the operator. The slide position can be adjusted by turning the screw with an ordinary wrench. The piece is damped by operating the lever on the air-oil multiplier. This makes them particularly suitable for mass-productions. Three models: MOD. 125 with 2500 Kg/F a 8 BAR - MOD. 150 with 4500 Kg/F a 8 BAR - MOD. 200 with 5500 Kg/F a 8 BAR

MORSE TIPO / VICES TYPE DSP. 81

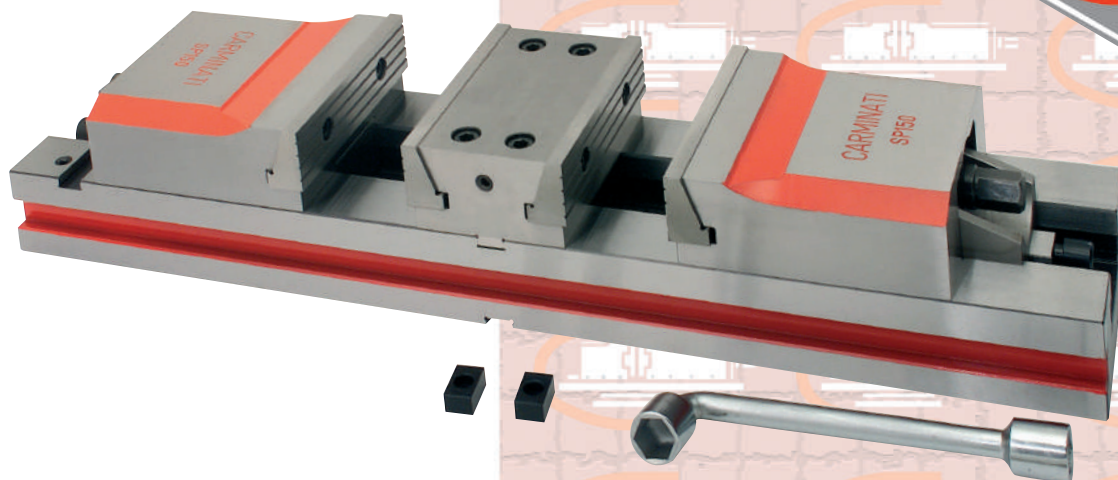

TIPO / TYPE DSP. 81

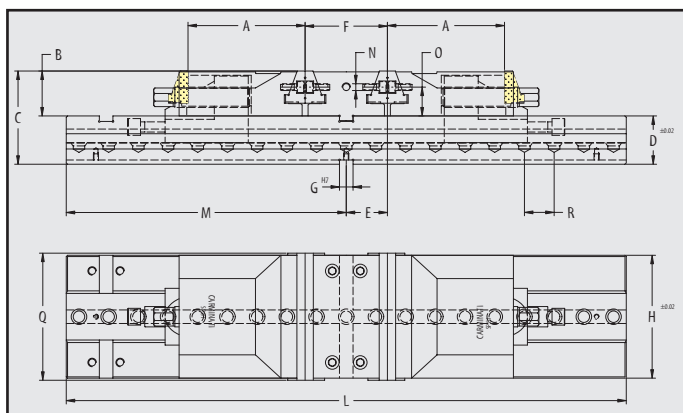

MOD	A	B	C	D	E	F	G	H	L	M	N	O	Q	R	Peso Kg.
100	82	39.5	79.5	40	37	74	14	95	470	235	M6	25.5	100	20	21
125	118	46	89	43	42.5	85	14	120	568	284	M6	30	125	27	32
150	138	53	110	57	48.5	97	16	145	660	330	M8	34	150	35	58
200	148	67	134	67	60	120	16	195	760	380	M8	43.5	200	40	116

TIPO / TYPE IDSP. - MDSP. 81

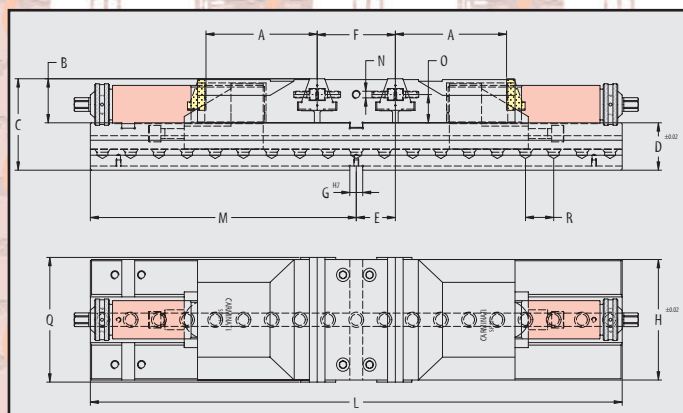

MOD	A	B	C	D	E	F	G	H	L	M	N	O	Q	R	Peso Kg.
100	82	39.5	79.5	40	37	74	14	95	470	235	M6	25.5	100	20	23.8
125	118	46	89	43	42.5	85	14	120	568	284	M6	30	125	27	34.8
150	138	53	110	57	48.5	97	16	145	660	330	M8	34	150	35	62
200	148	67	134	67	60	120	16	195	760	380	M8	43.5	200	40	120

Le morse tipo DSP81 sono strumenti di lavoro di altissima precisione, componibili tra loro e con la tradizionale SP81 consentono soluzioni ideali per risolvere varie situazioni di bloccaggio.

La DSP81 da considerarsi una doppia morsa per lavorazioni in serie.

Possono funzionare con bloccaggio meccanico (DSP81), meccanoidraulico (IDSP81), meccanico-meccanico (MDSP81) e oleopneumatico (ODSP81).

Il posizionamento del carro viene effettuato spingendo l'asta predisposta nella parte bassa della chiocciola. Ganasce discendenti con controllo del ritorno a zero.

Costruite in acciaio al cromo nichel temprate a 58 HRC, rettificata, assicurano la massima precisione e perfetto funzionamento.

Su richiesta possono essere fornite con ganasce ridotte per fissare la morsa sui fianchi.

The vices type DSP81 are high precision working tools, composable between each other and the traditional SP81, they are consenting solutions in various blocking situations.

The DSP81 is to be considered a double vice for processing in series.

They can function with mechanical blocking (DSP81), with mechanical hydraulic (IDSP81), with mechanical-mechanical (MDSP81) and oleopneumatic (ODSP81).

The position of the bogie is effected by pushing the lside bar arranged on the low part of the leadnut.

Descending jaws, jaw return control zero. All buildt in chromium nickel steel, hardened in 58 HRC, rectified.

They assure max precision and perfect function.

At request they can be supplied with reduced jaws to fix the vice sideways.

TIPO / TYPE ODSP. 81

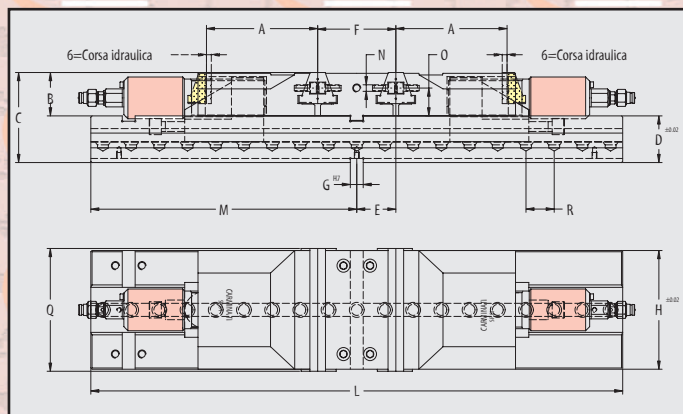

MOD	A	B	C	D	E	F	G	H	L	M	N	O	Q	R	Peso Kg.
125	118	46	89	43	42.5	85	14	120	568	284	M6	30	125	27	35
150	138	53	110	57	48.5	97	16	145	660	330	M8	34	150	35	62
200	148	67	134	67	60	120	16	195	760	380	M8	43.5	200	40	120

MORSE TIPO / VICES TYPE PSP. 81



TIPO / TYPE PSP. 81

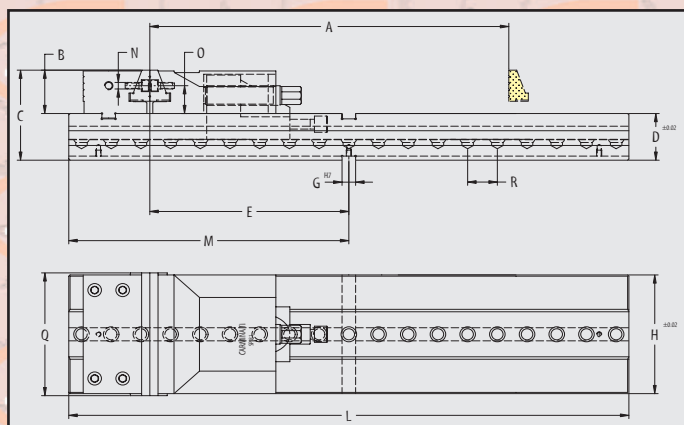

MOD	A	B	C	D	E	G	H	L	M	N	O	Q	R	Peso Kg.
100	280	39.5	79.5	40	163	14	95	470	235	M6	25.5	100	20	18
125	360	46	89	43	200.5	14	120	568	284	M6	30	125	27	28
150	421	53	110	57	234.5	16	145	660	330	M8	34	150	35	49
200	473	67	134	67	265	16	195	760	380	M8	43.5	200	40	97

TIPO / TYPE IPSP. - MPSP 81

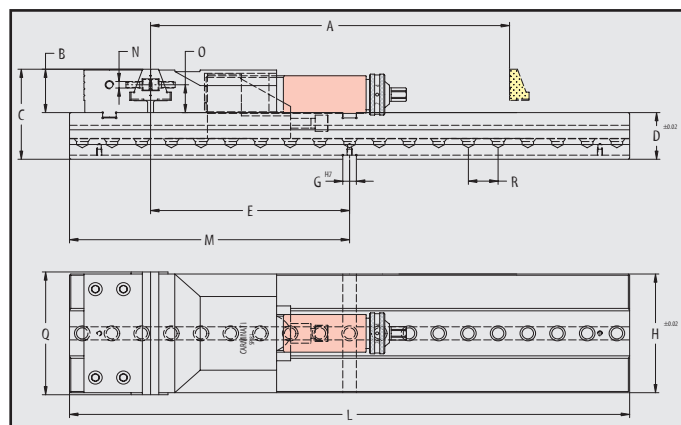

MOD	A	B	C	D	E	G	H	L	M	N	O	Q	R	Peso Kg.
100	280	39.5	79.5	40	163	14	95	470	235	M6	25.5	100	20	19.4
125	360	46	89	43	200.5	14	120	568	284	M6	30	125	27	29.4
150	421	53	110	57	234.5	16	145	660	330	M8	34	150	35	51
200	473	67	134	67	265	16	195	760	380	M8	43.5	200	40	99

TIPO / TYPE OPSP. 81

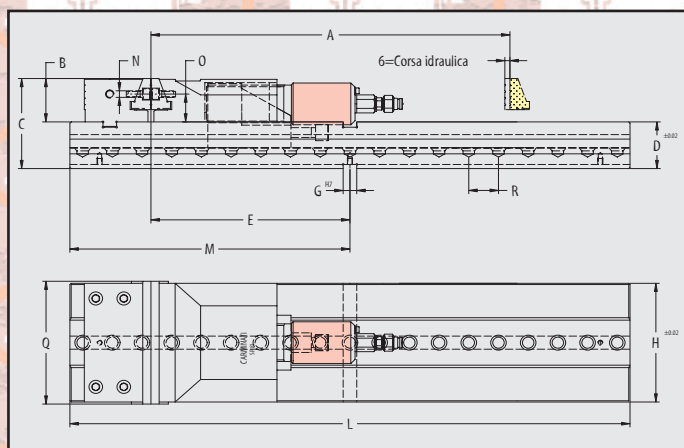

MOD	A	B	C	D	E	G	H	L	M	N	O	Q	R	Peso Kg.
125	360	46	89	43	200.5	14	120	568	284	M6	30	125	27	29.4
150	421	53	110	57	234.5	16	145	660	330	M8	34	150	35	51
200	473	67	134	67	265	16	195	760	380	M8	43.5	200	40	99

Le morse tipo PSP81 sono strumenti di lavoro di altissima precisione, componibili tra loro e con la tradizionale SP81 consentono soluzioni ideali per risolvere varie situazioni di bloccaggio.

La PSP. 81 la morsa ideale per bloccare pezzi con dimensioni insolite. Possono funzionare con bloccaggio meccanico (PSP81), meccanoidraulico (IPSP81), meccanico-meccanico (MPSP81) e oleopneumatico (OPSP81).

Il posizionamento del carro viene effettuato spingendo l'asta predisposta nella parte bassa della chiocciola. Ganasce discendenti con controllo del ritorno a zero.

Costruite in acciaio al cromo nichel temprate a 58 HRC, rettificate, assicurano la massima precisa e perfetto funzionamento.

Su richiesta possono essere fornite con ganasce ridotte per fissare la morsa sui fianchi.

The vices type PSP81 are high precision working tools, composable between each other and the traditional SP81, they are consenting solutions in various blocking situations.

The PSP81 is the ideal vice to block pieces with unusual dimensions. They can function with mechanical blocking (PSP81), with mechanical hydraulic (IPSP81), with mechanical-mechanical (MPSP81) and oleopneumatic (OPSP81).

The position of the bogie is effected by pushing the lside bar arranged on the low part of the leadnut.

Descending jaws, jaw return control zero. All built in chromium nickel steel, hardened in 58 HRC, rectified.

They assure max precision and perfect function.

At request they can be supplied with reduced jaws to fix the vice sideways.

PROLUNGHE /EXTENTIONS SP. 81

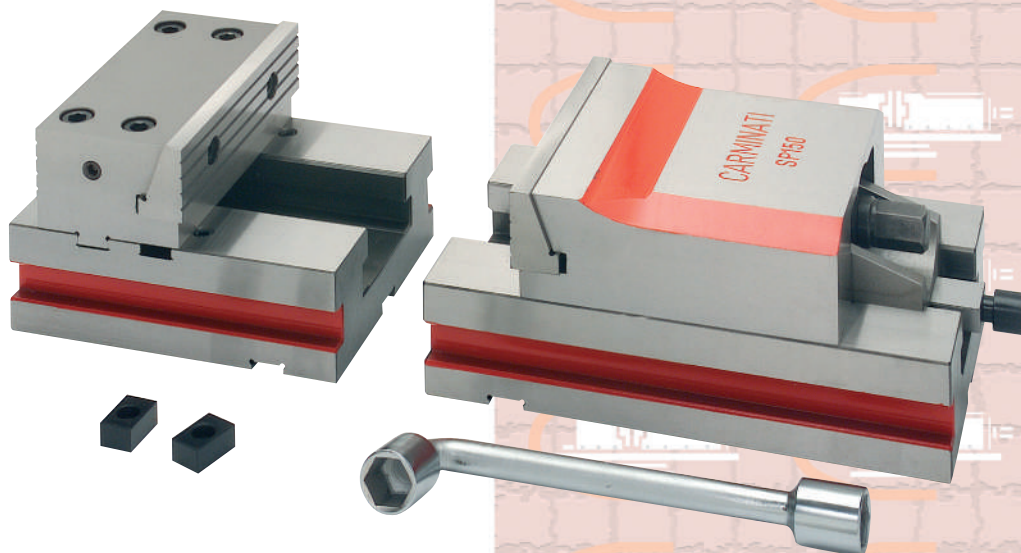

Impiego di prolunga MOBILE e prolunga FISSA per aumentare la profondit  della presa. Per bloccare pezzi di altezza elevata.
Use of a mobile extension A and fixed extension B to increase depth. To clamp long pieces.



Impiego di prolunga MOBILE e prolunga FISSA per aumentare la lunghezza della presa. Per bloccare pezzi di elevate dimensioni.
Use of a mobile extension A and fixed extension B to increase holding depth. For large size pieces.

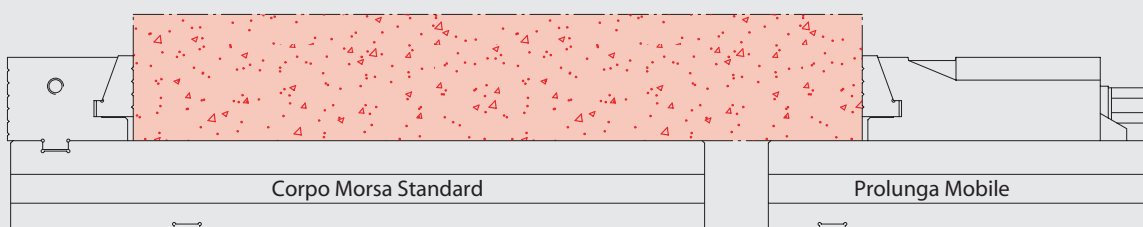

Impiego di MORSA e Prolunga MOBILE per pezzi di lunghezza insolita.
Use of a vice C and mobile extension A for pieces of unusual length.



COMPONENTI / COMPONENT PARTS SP. 81

CORPO PROLUNGATO/LENGTHENED BODY DSP - PSP 81

MOD	D	E	F	G	H	L	R
100	40	200	235	14	95	470	20
125	43	243	284	14	120	568	27
150	57	283	330	16	145	660	35
200	67	325	380	16	195	760	40

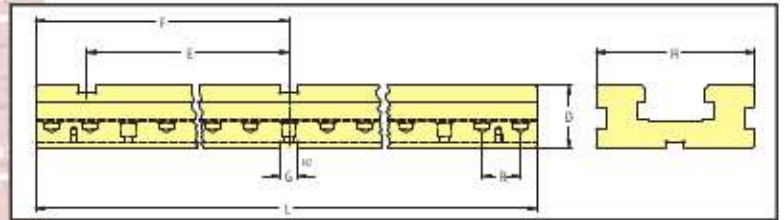

CORPO BASE/BASIC BODY SP. 81

MOD	L	H	M	G	D	R
100	314,5	95	157,25	14	40	20
125	366	120	183	14	43	27
150	449	145	224,5	16	57	35
200	613	195	306,5	16	67	40

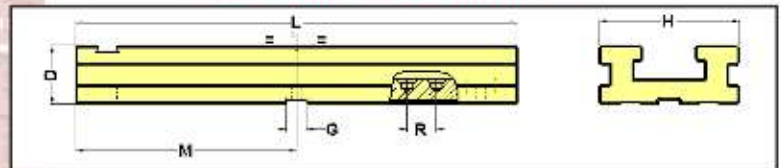

PROLUNGA MOBILE/MOBILE EXTENSION SP. 81

MOD	L	H	M	G	D	S	P	R
100	175	95	35	14	40	64	57	20
125	190	120	35	14	43	84	60	27
150	240	145	40	16	57	107	93	35
200	284	195	40	16	67	123	106	40

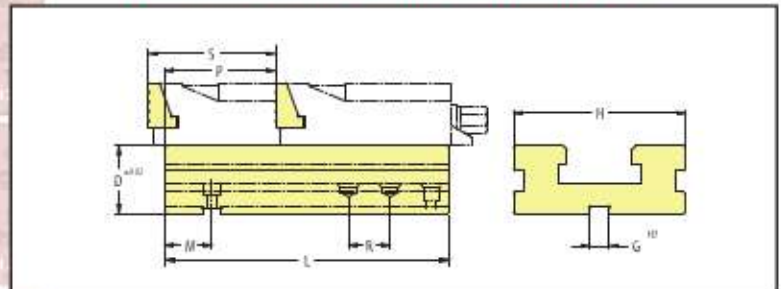

PROLUNGA FISSA/FIXED EXTENSION SP. 81

MOD	L	H	M	G	D	S	P
100	130	95	35	14	40	25	23
125	150	120	35	14	43	30	28
150	170	145	35	16	57	33	29
200	200	195	35	16	67	42	38

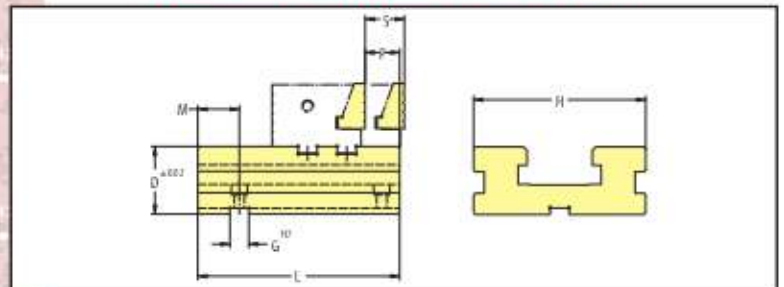

FISSO DOPPIO/DOUBLE FIXED DSP 81

MOD	B	L	S
100	40	95	74
125	46	120	85
150	53	145	97
200	67	195	120

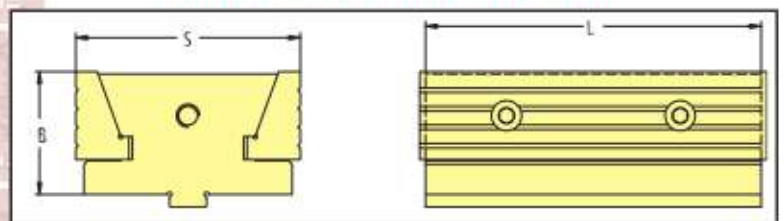

FISSO/FIXED SP. 81

MOD	B	L	S
100	40	95	72,5
125	46	120	83,5
150	53	145	93,5
200	67	195	115

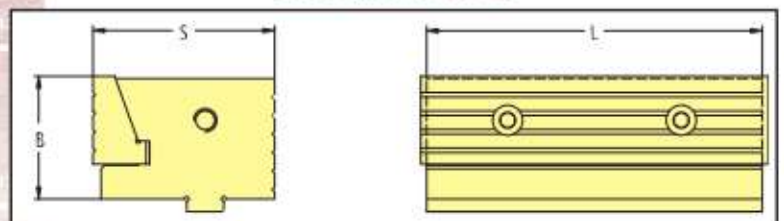

COMPONENTI / COMPONENT PARTS SP. 81



CARRELLO/TROLLEY SP. - DSP. - PSP. 81

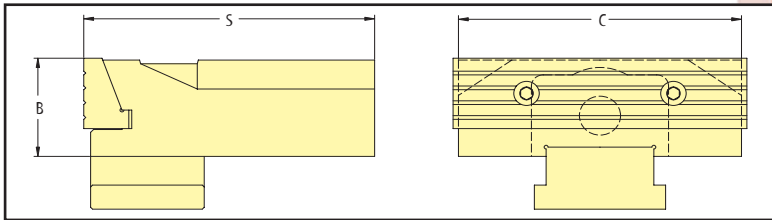

MOD	B	C	S
100	40	95	96.5
125	46	120	121.5
150	53	145	148.5
200	67	195	185

GANASCIA A GRADINO/STEPPED JAW SP. 81

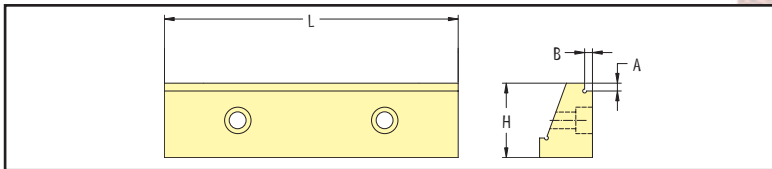

MOD	A	B	H	L
100	4	4	28	100
125	4	4	32	125
150	5	4	38	150
200	5	4	47	200

GANASCIA A V/V-JAW SP. 81

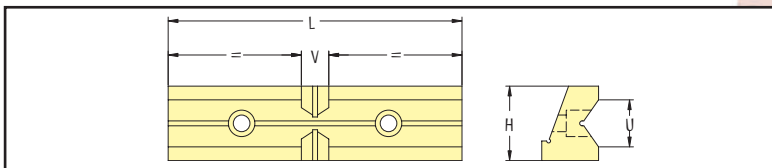

MOD	L	H	U	V
100	100	28	20x110i	12x110i
125	125	32	20x110i	12x110i
150	150	38	20x110i	14x110i
200	200	47	20x110i	14x110i

GANASCIA PORTA BLOCCHETTO/BLOCK CARRIER JAW SP. 81

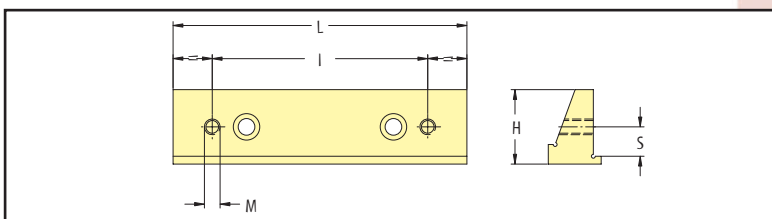

MOD	L	H	I	S	M
100	100	28	75	10	M6
125	125	32	90	12	M6
150	150	38	110	15	M8
200	200	47	100	19.5	M8

BLOCCHETTO TENERO/SOFT BLOCK SP. 81

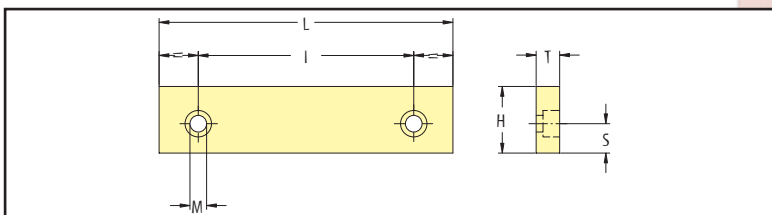

MOD	L	H	I	S	M	T
100	100	24	75	10	x M6	10
125	125	28	90	12	x M6	10
150	150	34	110	15	x M8	12
200	200	43	100	19.5	x M8	12

BASE GIREVOLE/ROTATING BASE SP. 81

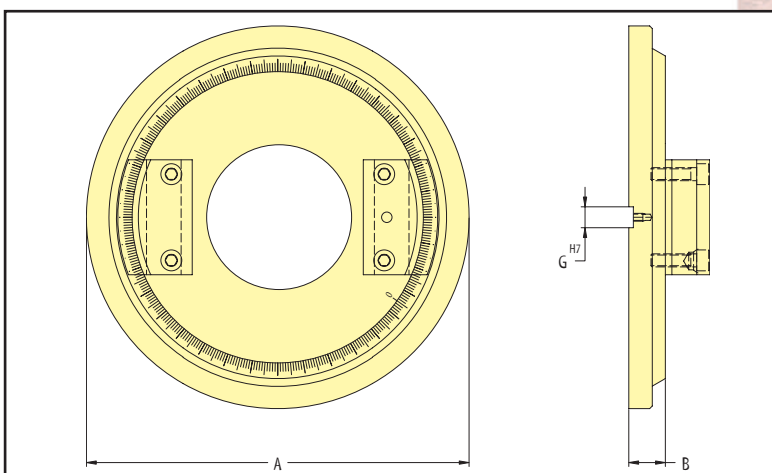

MOD	A	B	G
100	∅205	23	14
125	∅238	27	14
150	∅293	28	16
200	∅343	34	16



COMPONENTI / COMPONENT PARTS SP. 81

FRUPPO MECCANICO/MECHANICAL UNIT SP. 81

MOD	Corsa vite
100	22
125	27
150	38
200	43

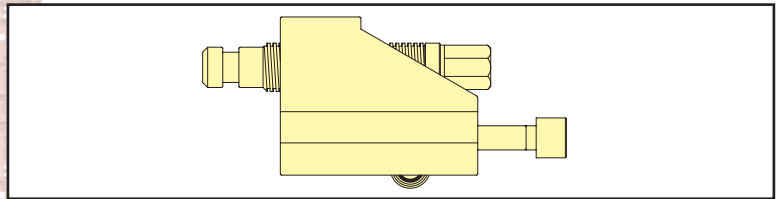

GRUPPO MECCANIDRAULICO/MECHANICAL-HYDRAULIC UNIT ISP. - MSP. 81

MOD	L	F	Corsa vite
100	215	M28	22
125	232	∅36 TpN	27
150	278	∅46 TpN	38
200	278	∅46 TpN	43

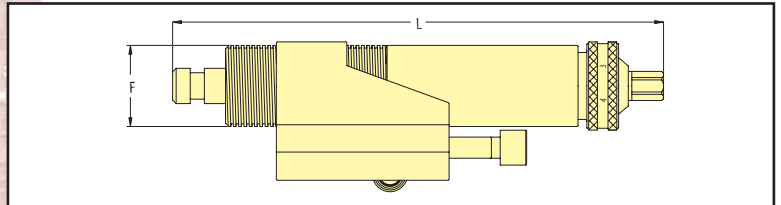

GRUPPO OLEOPNEUMATICO/OIL-HYDRAULIC UNIT OSP. 81

MOD	L	F	Corsa vite	C
125	187	∅36 TpN	27	6
150	230	∅46 TpN	38	6
200	230	∅46 TpN	43	6

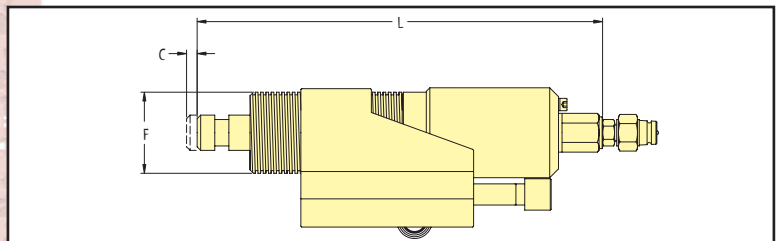

STAFFE BASAMENTO/BASE BRACKET SP. 81

MOD	A	B	C	D	E
100	11.5	13.5	17	23	x M12
125	13	14	18	27	x M12
150	16	18	19	39	x M12
200	15	24	22	36	x M12

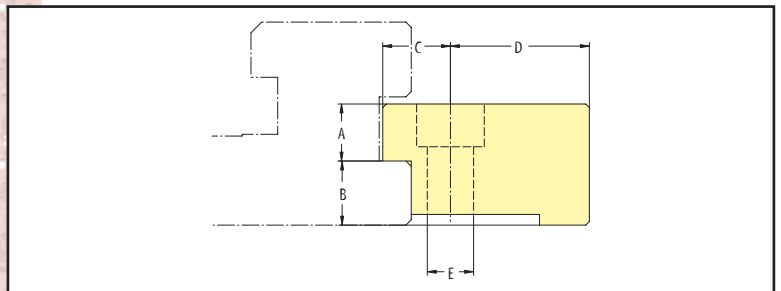

STAFFE PIATTELLO/PLATE BRACKETS SP. 81

MOD	A	C	L	D	H
100	14	23	65	x M12	14
125	14	23	65	x M12	14
150	15	27.5	78	x M12	18
200	15	33.5	78	x M12	24

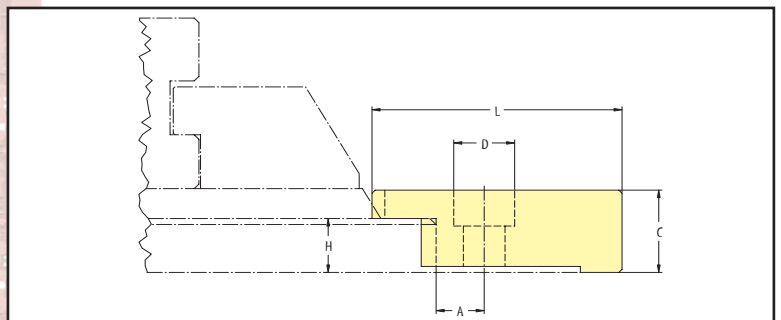

GUIDA RIFERIMENTO/REFERENCE GUIDE SP. 81

MOD	A	C	D	H	L	F	B
100	14	6	6	12	25	x M6	A Richiesta
125	14	6	6	12	25	x M6	A Richiesta
150	16	6	6	12	25	x M6	A Richiesta
200	16	6	6	12	25	x M6	A Richiesta

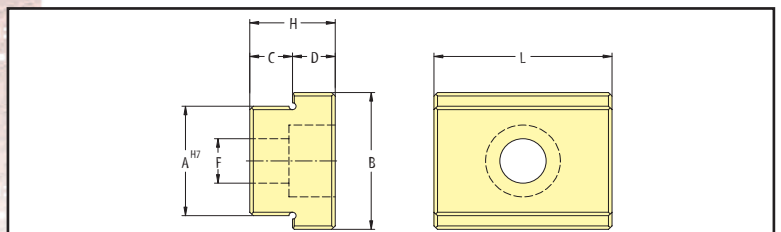

MORSE TIPO / VICES TYPE SPE. 81

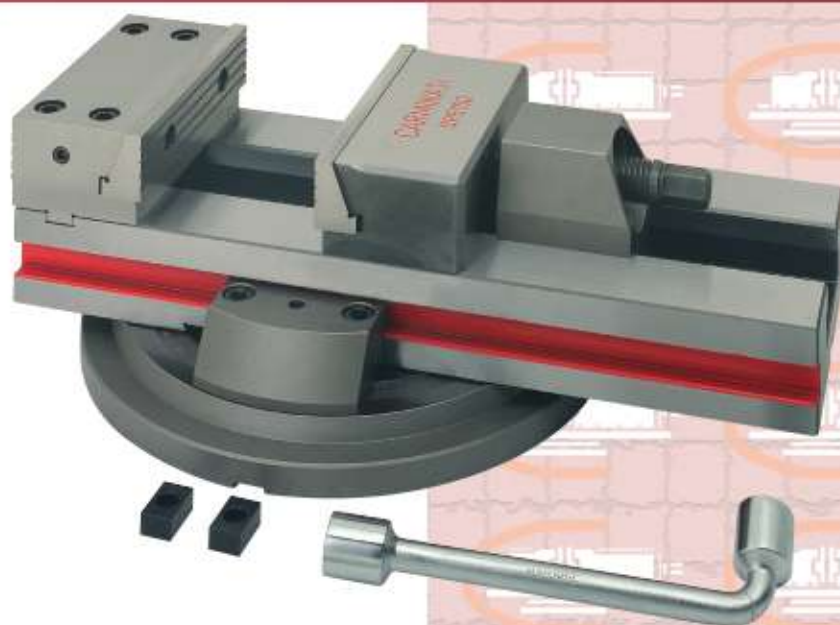

TIPO / TYPE SPE. 81

MOD	100	125	150	200
A	120	159	210	320
B	39,5	46	53	67
C	79,5	89	110	134
D	40	43	57	67
E	84,8	99,54	131,04	191,54
F	102,5	116	138	168
G	14	14	16	16
H	95	120	145	195
L	314,5	366	449	613
M	157,25	183	224,5	306,5
N	M6	M6	M8	M8
O	25,5	30	34	43,5
P	205	238	293	343
Q	100	125	150	200
R	20	27	35	40
Peso Kg.	17	27	48,3	94,6

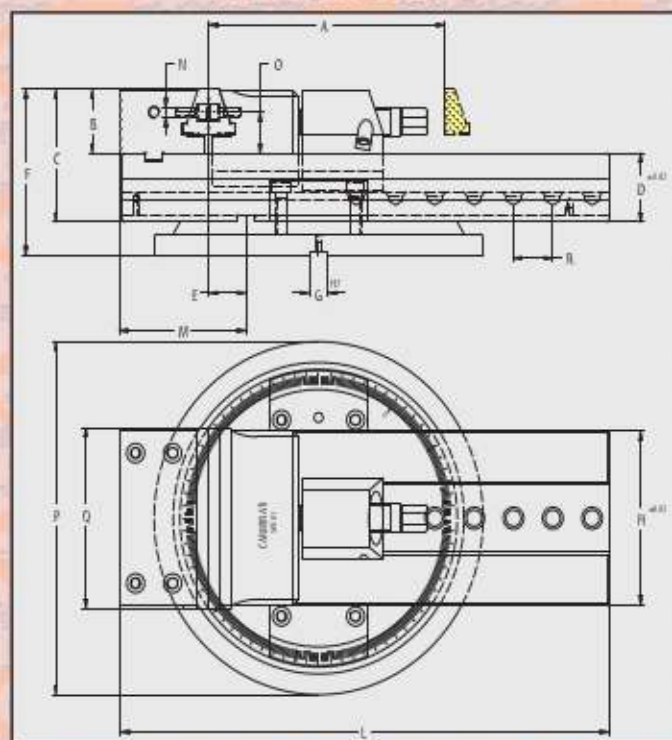

LE MORSE TIPO SPE81 ECONOMIC di altissima precisione sono costruite in acciaio al nichel temprato. Sono componibili fra loro e con i tipi SP81 dai quali si differenziano per carrello e chiocciola. Caratteristiche principali: - ganasce discendenti che bloccano in qualsiasi posizione il pezzo sul piano della morsa - controllo ritorno delle ganasce e grande apertura. Sono particolarmente indicate per attrezzisti e stampisti. Rettificate in tutti i particolari che le compongono, garantiscono la massima precisione. Vengono prodotte in quattro modelli.

HIGH PRECISION SPE81 economic vices are made of hardened nickel steel. The vice is fitted with optional components. The difference from type SP81 is the winding trolley. Main features: - Descending jaws that clamp the piece on the plate under any conditions; - Jaw return control and wide opening they are particularly useful for toolmakers and for pressing. All parts are grinded, which ensures maximum precision. They come in four models.



MORSE TIPO / VICES TYPE ISPE. 81 - OSPE. 81

TIPO / TYPE ISPE. - MSPE. 81

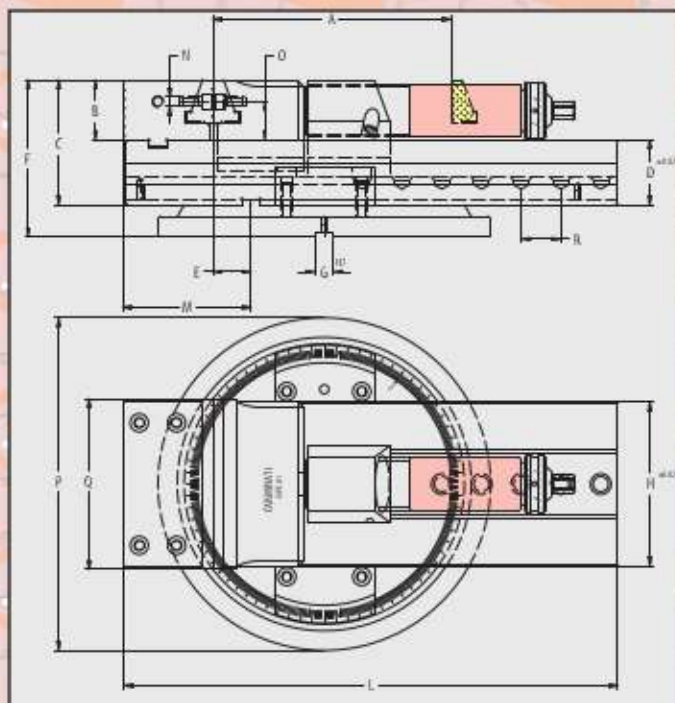

MOD	A	B	C	D	E	F	G	H	L	M	N	O	P	Q	R	Peso Kg.
100	120	39,5	79,5	40	84,8	102,5	14	95	314,5	157	M6	25,5	205	100	20	17
125	159	46	89	43	99,54	116	14	120	366	183	M6	30	238	125	27	27
150	210	53	110	57	131,04	138	16	145	449	224,5	M8	34	293	150	35	48,3
200	320	67	134	67	191,54	168	16	195	613	306,5	M8	43,5	343	200	40	94,6

 **LE MORSE SPE 81 ECONOMIC** con bloccaggio mecano-idraulico si chiamano **ISPE 81**, con il bloccaggio mecano-meccanico sono le **MSPE81**. Scegliendo, per mezzo del nonio inciso sulla vite, la spinta necessaria per la lavorazione si ottiene sempre un bloccaggio costante. Sono prodotte in quattro modelli: MOD. 100 Kg/F 2000 - MOD. 125 Kg/F 3000 - MOD. 150 Kg/F 4000 - MOD. 200 Kg/F 5000

 **THE SPE81 ECONBOMIC** vice with mechanical-hydraulic dosure is called **ISPE81**, with mechanical-mechanical closure is called **MSPE81**. Mechanical-hydraulic multiplier inserted in the screw ensure a quick and safe clamping without excessive work. They come in three models: Model 125 with 3000 Kg/F - Model 150 with 4500 Kg/F - Model 200 with 5000 Kg/F

TIPO / TYPE OSPE. 81

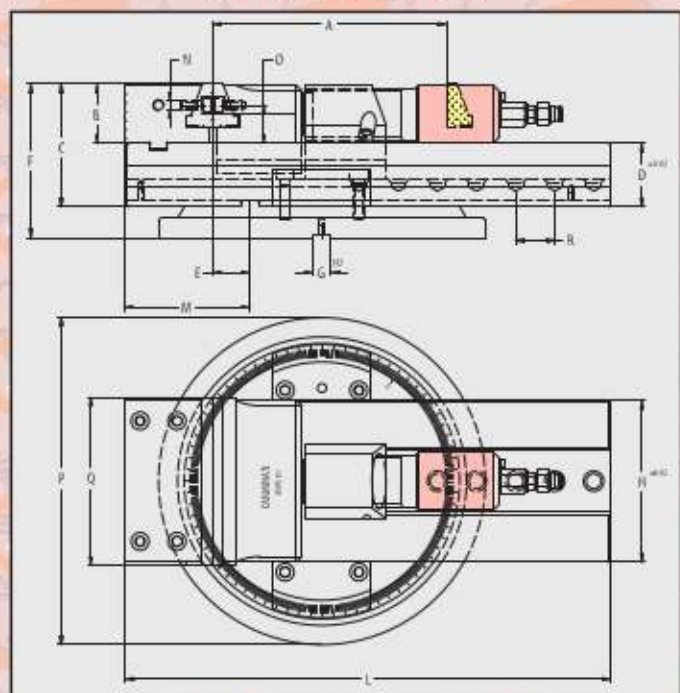

MOD	A	B	C	D	E	F	G	H	L	M	N	O	P	Q	R	Peso Kg.
125	159	46	89	43	99,54	116	14	120	366	183	M6	30	238	125	27	27
150	210	53	110	57	131,04	138	16	145	449	224,5	M8	34	293	150	35	48,3
200	320	67	134	67	191,54	168	16	195	613	306,5	M8	43,5	343	200	40	94,6

 **LE MORSE SPE81 ECONOMIC** con bloccaggio oleo pneumatico si chiamano **OSPE81**. Mediante un cilindro idraulico inserito nella vite ed un moltiplicatore di pressione aria-olio il bloccaggio rapido e sicuro, senza affaticamento dell'operatore. La posizione del carro regolata mediante la rotazione della vite con una semplice chiave. Il bloccaggio del pezzo comandato mediante l'azionamento della valvola sul moltiplicatore aria-olio. Sono ottimali per lavorazioni di serie. La corsa oleodinamica di mm. 6. Sono prodotte in tre modelli: MOD. 125 con 2500 Kg./F a 8 bar - MOD. 150 con 4500 Kg./F a 8 bar - MOD. 200 con 5000 Kg./F a 8 bar

 **OSPE81 VICES TYPE SPE81 ECONOMIC, SPE81 ECONOMIC** vices with oleopneumatic closure are called **OSP81**. A hydraulic cylinder inserted in the screw and an air-oil pressure multiplier ensure quick and safe clamping, without excessive work for the operator. The slide position can be adjusted by turning the screw with an ordinary wrench. The piece is clamped by operating the lever on the air-oil multiplier. This makes them particularly suitable for mass-productions. MOD. 125 with 2500 Kg/F a 8 BAR. - MOD. 150 with 4500 Kg/F a 8 BAR. - MOD. 200 with 5000 Kg/F a 8 BAR.

MORSE TIPO / VICES TYPE DSPE. 81

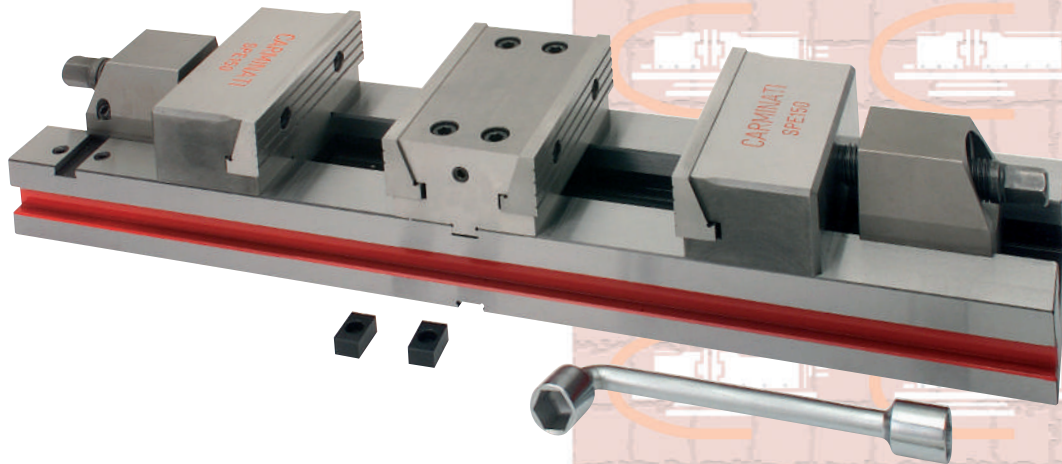

TIPO / TYPE IDSPE. - MDSPE. 81

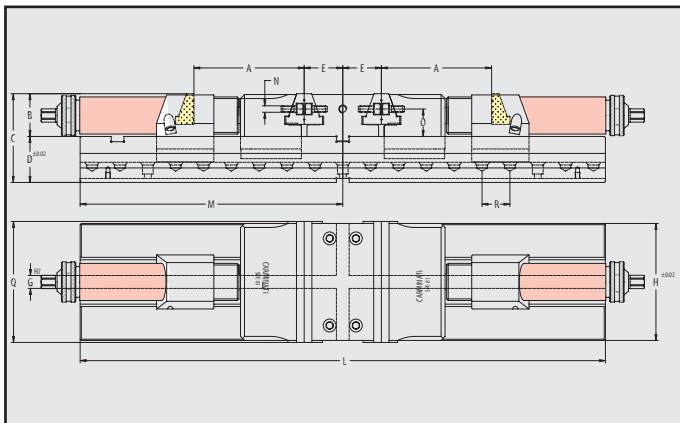

MOD	A	B	C	D	E	G	H	L	M	N	O	Q	R	Peso Kg.
100	81	39.5	79.5	40	37	14	95	470	235	M6	25.5	100	20	23
125	117	46	89	43	42.5	14	120	568	284	M6	30	125	27	35
150	138	53	110	57	48.5	16	145	660	330	M8	34	150	35	61
200	148	67	134	67	60	16	195	760	380	M8	43.5	200	40	112

TIPO / TYPE DSPE. 81

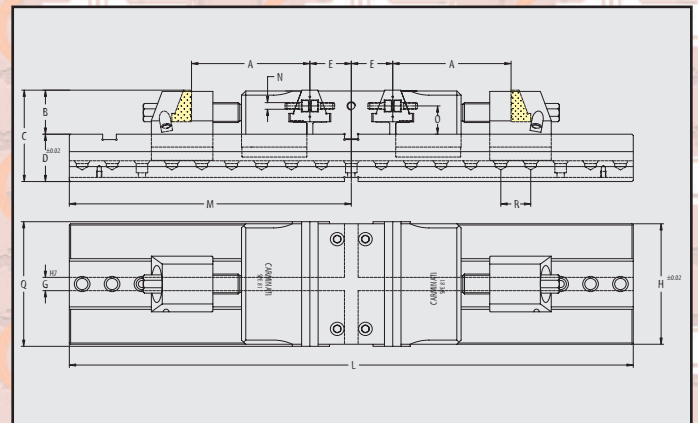

MOD	A	B	C	D	E	G	H	L	M	N	O	Q	R	Peso Kg.
100	81	39.5	79.5	40	37	14	95	470	235	M6	25.5	100	20	21
125	117	46	89	43	42.5	14	120	568	284	M6	30	125	27	32
150	138	53	110	57	48.5	16	145	660	330	M8	34	150	35	57
200	148	67	134	67	60	16	195	760	380	M8	43.5	200	40	108

 Le morse tipo DSPE81 si differenziano dai tipi DSP81 nel carrello e nella chiodi. Sono compatibili tra loro e con il tipo SPE81, vengono utilizzate per le stesse lavorazioni delle DSP81.

Possono funzionare con bloccaggio meccanico (DSPE81), meccanoidraulico (IDSPE81), meccanico-meccanico (MDSPE81) e oleopneumatico (ODSPE81).

Ganasce discendenti con controllo di ritorno a zero. Costruite in acciaio al cromo nichel, temprate a 58 HRC e rettificate, assicurano la massima precisione e perfetto funzionamento. Su richiesta possono essere fornite con ganasce ridotte per fissare la morsa sui fianchi.

 The vices type DSPE81 are different from DSP81 in the screw nut and the bogie.

Compatible to each other and with type SPE81, used in the same working as DSP81. They function with mechanical blocking (DSPE81) mechanical hydraulic (IDSPE81), mechanical-mechanical (MDSPE81) and oleopneumatic (ODSPE81).

Descending jaws, jaw return control zero.

Built in chromium nickel steel, hardened in 58 HRC, rectified.

They assure max precision and perfect function.

At request they can be supplied with reduced jaws to fix the vice sideways.

TIPO / TYPE ODSPE. 81

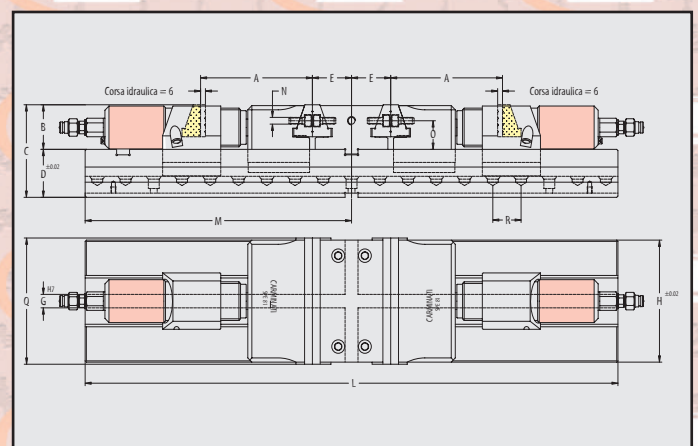

MOD	A	B	C	D	E	G	H	L	M	N	O	Q	R	Peso Kg.
125	117	46	89	43	42.5	14	120	568	284	M6	30	125	27	35
150	138	53	110	57	48.5	16	145	660	330	M8	34	150	35	61
200	148	67	134	67	60	16	195	760	380	M8	43.5	200	40	112



MORSE TIPO / VICES TYPE PSPE. 81

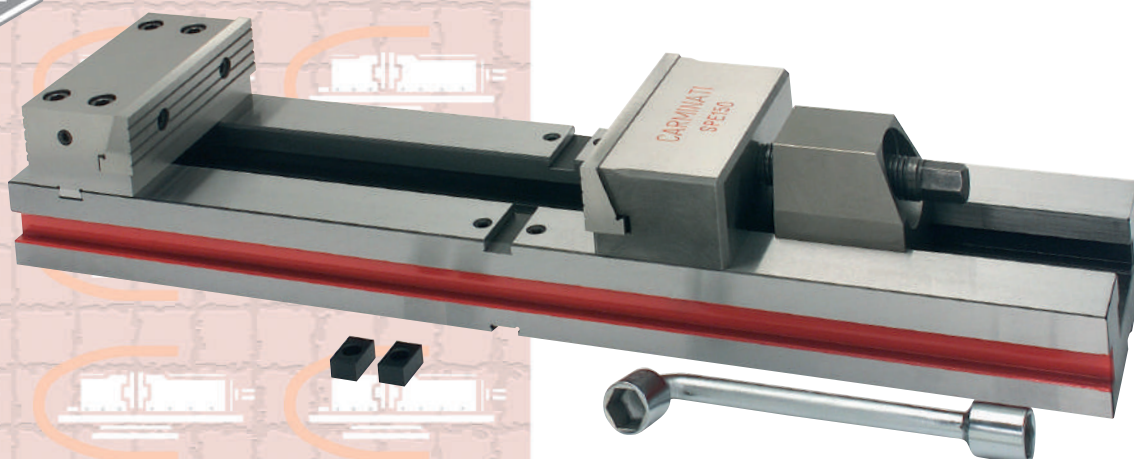

TIPO / TYPE IPSPE. - MPSPE. 81

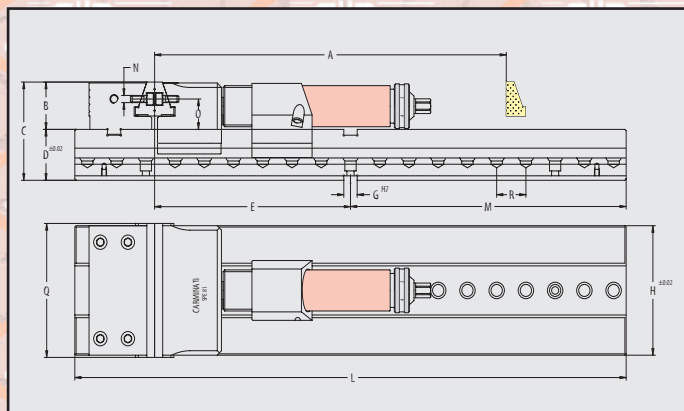

MOD	A	B	C	D	E	G	H	L	M	N	O	Q	R	Peso Kg.
100	281	39.5	79.5	40	163	14	95	470	235	M6	25.5	100	20	19.5
125	360	46	89	43	200.5	14	120	568	284	M6	30	125	27	28.5
150	421	53	110	57	234.5	16	145	660	330	M8	34	150	35	50
200	473	67	134	67	265	16	195	760	380	M8	43.5	200	40	95

TIPO / TYPE PSPE. 81

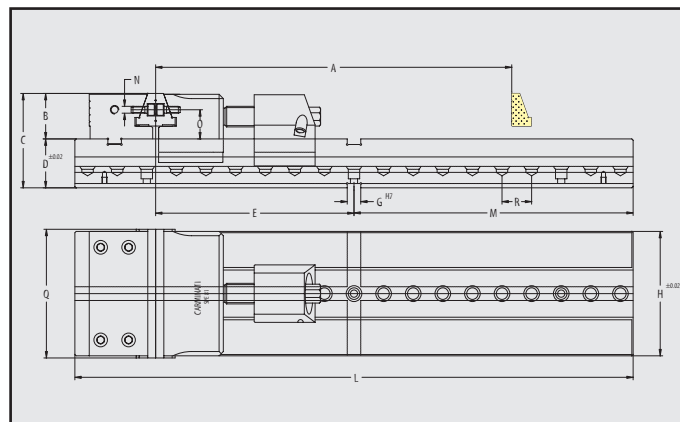

MOD	A	B	C	D	E	G	H	L	M	N	O	Q	R	Peso Kg.
100	281	39.5	79.5	40	163	14	95	470	235	M6	25.5	100	20	18
125	360	46	89	43	200.5	14	120	568	284	M6	30	125	27	28
150	421	53	110	57	234.5	16	145	660	330	M8	34	150	35	48
200	473	67	134	67	265	16	195	760	380	M8	43.5	200	40	93

TIPO / TYPE OPSPE. 81

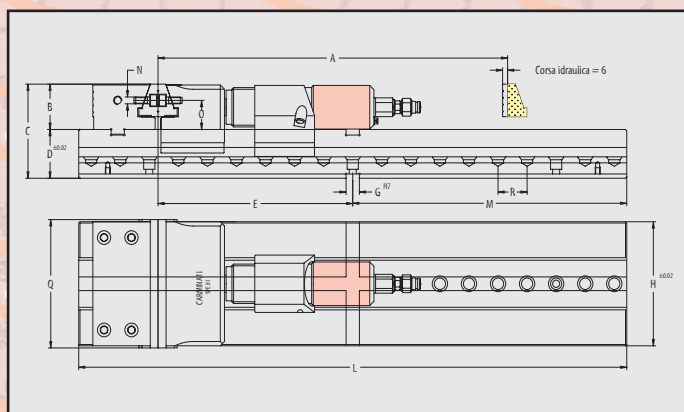

MOD	A	B	C	D	E	G	H	L	M	N	O	Q	R	Peso Kg.
125	360	46	89	43	200.5	14	120	568	284	M6	30	125	27	29.5
150	421	53	110	57	234.5	16	145	660	330	M8	34	150	35	50
200	473	67	134	67	265	16	195	760	380	M8	43.5	200	40	95

Le morse tipo PSPE81 si differenziano dai tipi PSP81 nel carrello e nella chiocciola. Sono compatibili tra loro e con il tipo SPE81, vengono utilizzate per le stesse lavorazioni delle PSP81.

Possono funzionare con bloccaggio meccanico (PSPE81), meccanoidraulico (IPSPE81), meccanico-meccanico (MPSPE81) e oleopneumatico (OPSPE81).

Ganasce discendenti con controllo di ritorno a zero. Costruite in acciaio al cromo nichel, temprate a 58 HRC e rettificate, assicurano la massima precisione e perfetto funzionamento. Su richiesta possono essere fornite con ganasce ridotte per fissare la morsa sui fianchi.

The vices type PSPE81 are different from PSP81 in the screw nut and the bogie.

Compatible to each other and with type SPE81, used in the same working as PSP81. They function with mechanical blocking (PSPE81) mechanical hydraulic (IPSPE81), mechanical-mechanical (MPSPE81) and oleopneumatic (OPSPE81).

Descending jaws, jaw return control zero. Built in chromium nickel steel, hardened in 58 HRC, rectified.

They assure max precision and perfect function.

At request they can be supplied with reduced jaws to fix the vice sideways.

PROLUNGHE / EXTENSIONS SPE. 81

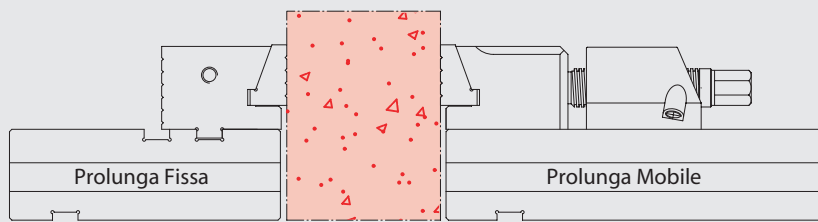
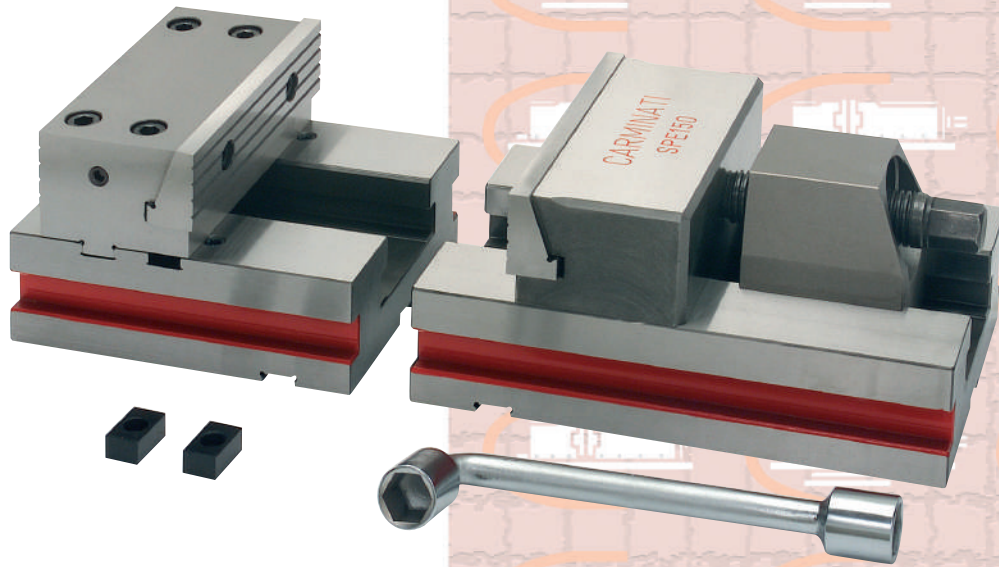

Impiego di prolunga MOBILE e prolunga FISSA per aumentare la profondità della presa. Per bloccare pezzi di altezza elevata.
Use of a mobile extension A and fixed extension B to increase depth. To clamp long pieces.

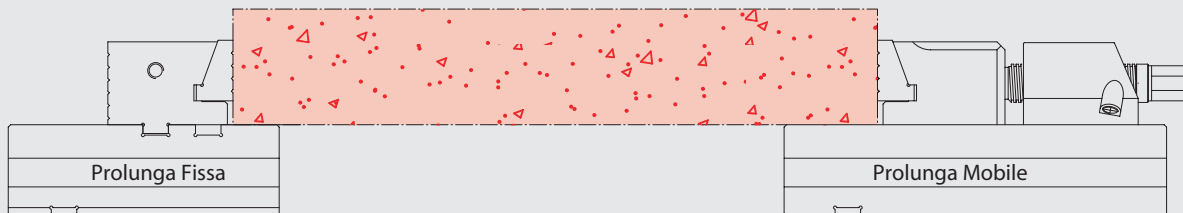

Impiego di prolunga MOBILE e prolunga FISSA per aumentare la lunghezza della presa. Per bloccare pezzi di elevate dimensioni.
Use of a mobile extension A and fixed extension B to increase holding depth. For large size pieces.

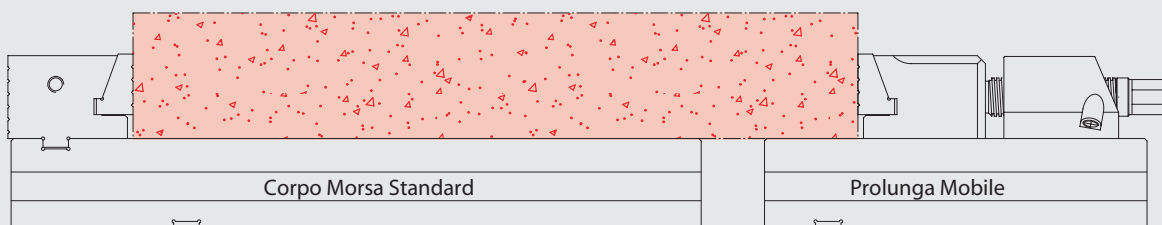

Impiego di MORSA e Prolunga MOBILE per pezzi di lunghezza insolita.
Use of a vice C and mobile extension A for pieces of unusual length.



COMPONENTI / COMPONENT PARTS SPE. 81

MOD	D	E	F	G	H	L	R
100	40	200	235	14	95	470	20
125	43	243	284	14	120	568	27
150	57	283	330	16	145	660	35
200	67	325	380	16	195	760	40

CORPO PROLUNGATO/LENGTHENED BODY DSPE. PSPE. 81

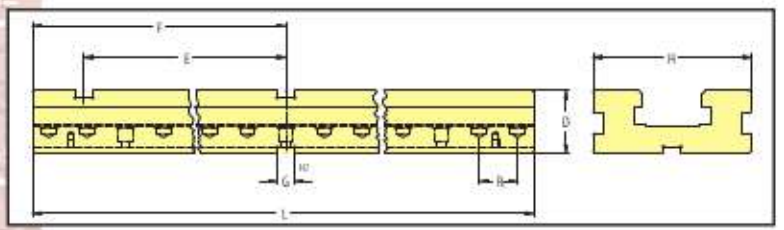

MOD	L	H	M	G	D	R
100	314,5	95	157,25	14	40	20
125	366	120	183	14	43	27
150	449	145	224,5	16	57	35
200	613	195	306,5	16	67	40

CORPO BASE/BASIC BODY SPE. 81

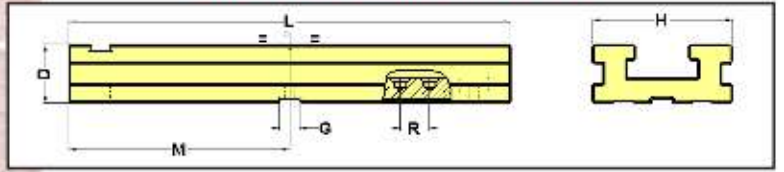

MOD	L	H	M	G	D	S	P	R
100	175	95	35	14	40	64	57	20
125	190	120	35	14	43	84	60	27
150	240	145	40	16	57	107	93	35
200	284	195	40	16	67	123	106	40

PROLUNGA MOBILE/MOBILE EXTENSION SPE. 81

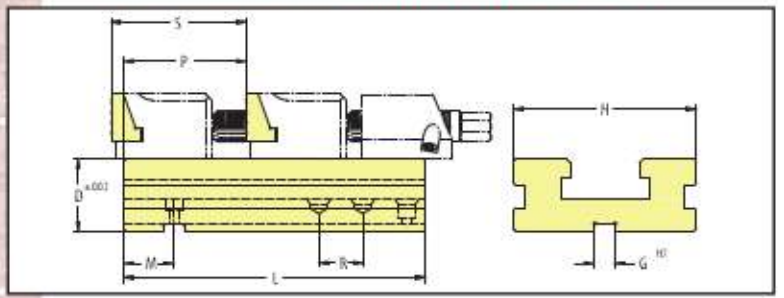

MOD	L	H	M	G	D	S	P
100	130	95	35	14	40	25	23
125	150	120	35	14	43	30	28
150	170	145	35	16	57	33	29
200	200	195	35	16	67	42	38

PROLUNGA FISSA/FIXED EXTENSION SPE. 81

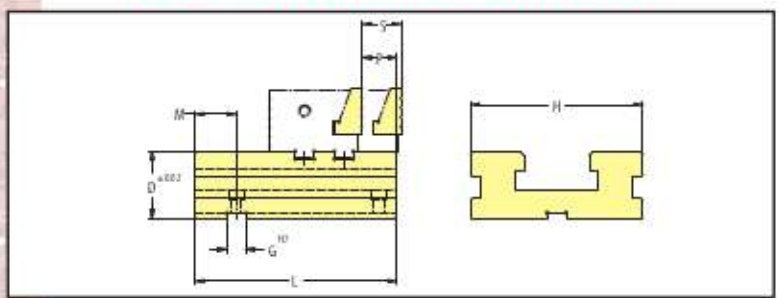

MOD	B	L	S
100	40	95	74
125	46	120	85
150	53	145	97
200	67	195	120

FISSO DOPPIO/DOUBLE FIXED DSPE. 81

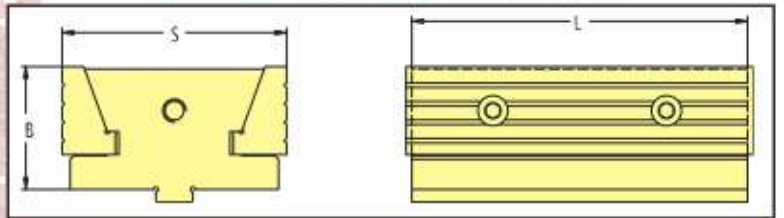

MOD	B	L	S
100	40	95	72,5
125	46	120	83,5
150	53	145	93,5
200	67	195	115

FISSO/FIXED SPE. 81

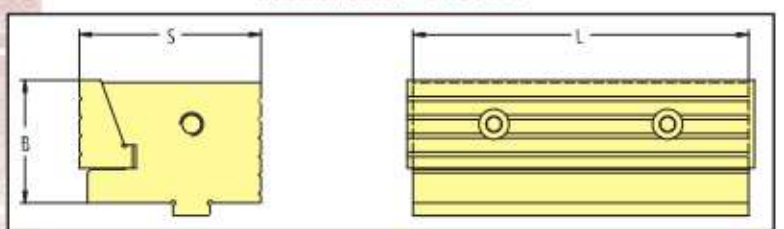

COMPONENTI / COMPONENT PARTS SPE. 81



CARRELLO/TROLLEY SPE. - DSPE. - PSPE. 81

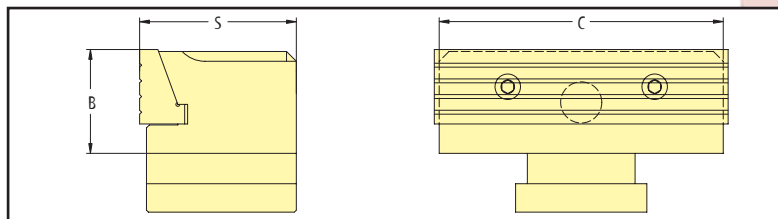

MOD	B	C	S
100	40	95	64
125	46	120	72
150	53	145	80
200	67	195	103.5

GANASCIA A GRADINO/STEPPED JAW SPE. 81

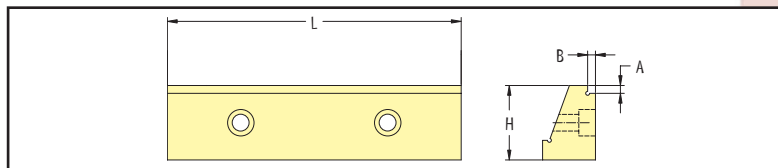

MOD	A	B	H	L
100	4	4	28	100
125	4	4	32	125
150	5	4	38	150
200	5	4	47	200

GANASCIA A V/V-JAW SPE. 81

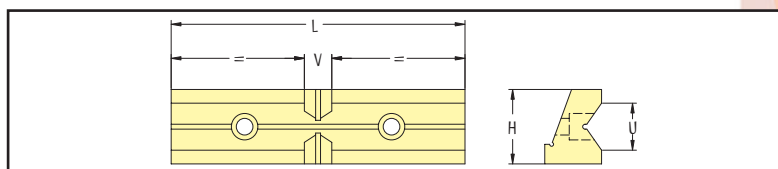

MOD	L	H	U	V
100	100	28	20x110i	12x110i
125	125	32	20x110i	12x110i
150	150	38	20x110i	14x110i
200	200	47	20x110i	14x110i

GANASCIA PORTA BLOCCHETTO/BLOCK CARRIER JAW SPE. 81

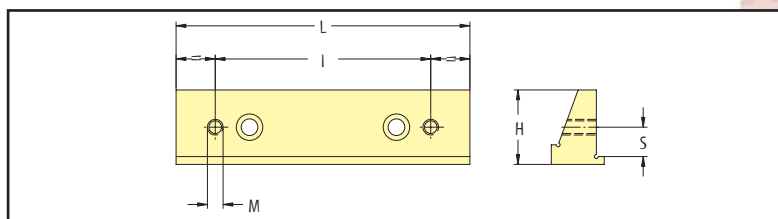

MOD	L	H	I	S	M
100	100	28	75	10	M6
125	125	32	90	12	M6
150	150	38	110	15	M8
200	200	47	100	19.5	M8

BLOCCHETTO TENERO/SOFT BLOCK SPE. 81

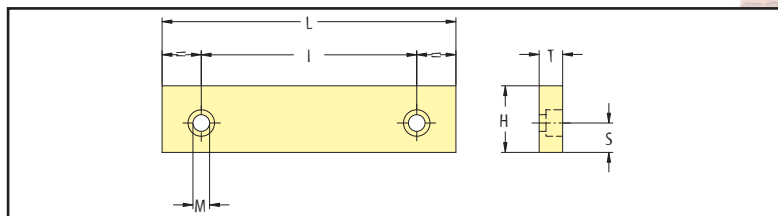

MOD	L	H	I	S	M	T
100	100	24	75	10	x M6	10
125	125	28	90	12	x M6	10
150	150	34	110	15	x M8	12
200	200	43	100	19.5	x M8	12

GRUPPO MECCANICO/MECHANICAL UNIT SPE. 81

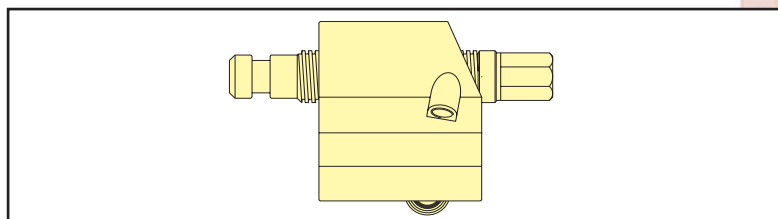

MOD	Corsa vite
100	22
125	27
150	38
200	43

GRUPPO MECCANIDRAULICO/MECHANICAL-HYDRAULIC UNIT ISPE. MSPE. 81

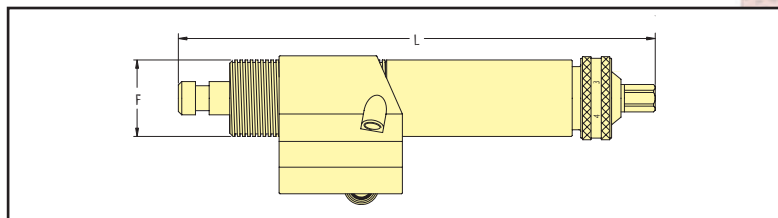

MOD	L	F	Corsa vite
100	215	M28	22
125	232	i36 TpN	27
150	278	i46 TpN	38
200	278	i46 TpN	43



COMPONENTI / COMPONENT PARTS SPE. 81

GRUPPO OLEODINAMICO/OIL-HYDRAULIC UNIT OSPE. 81

MOD	L	F	Corsa vite	C
125	187	∅36 TpN	27	6
150	230	∅46 TpN	38	6
200	230	∅46 TpN	43	6

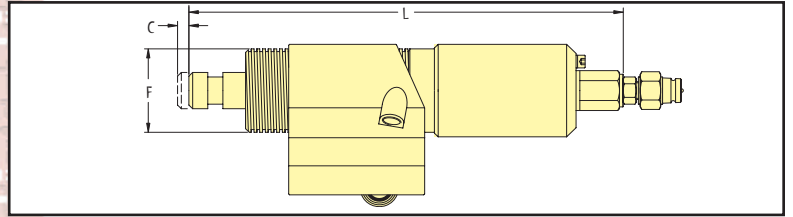

BASE GIREVOLE/ROTATING BASE SPE. 81

MOD	A	B	G
100	∅205	23	14
125	∅238	27	14
150	∅293	28	16
200	∅343	34	16

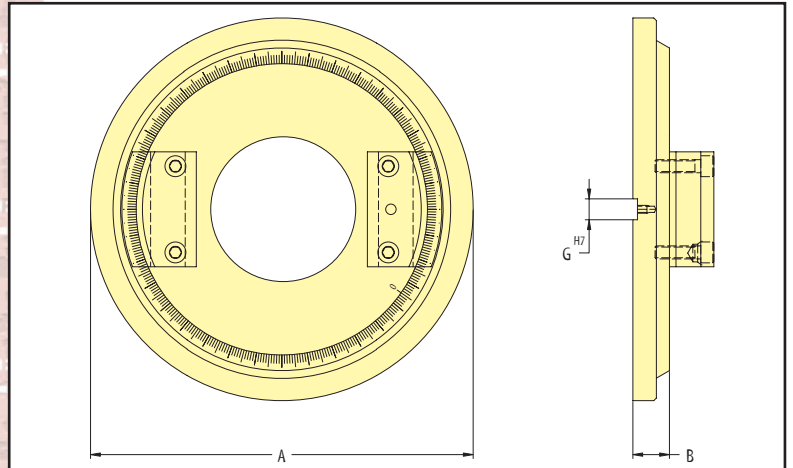

STAFFE BASAMENTO/BASE BRACKET SPE. 81

MOD	A	B	C	D	E
100	11.5	13.5	17	23	x M12
125	13	14	18	27	x M12
150	16	18	19	39	x M12
200	15	24	22	36	x M12

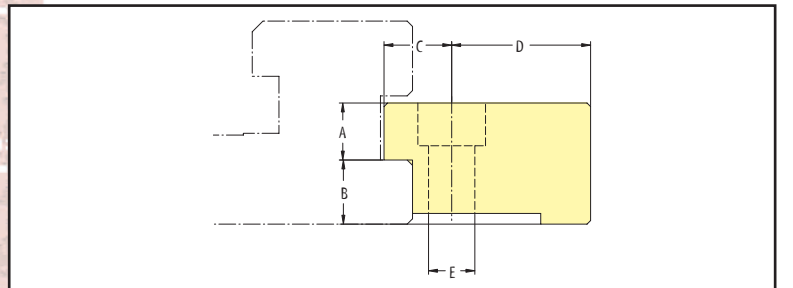

STAFFE PIATTELLO/PLATE BRACKETS SPE. 81

MOD	A	C	L	D	H
100	14	23	65	x M12	14
125	14	23	65	x M12	14
150	15	27.5	78	x M12	18
200	15	33.5	78	x M12	24

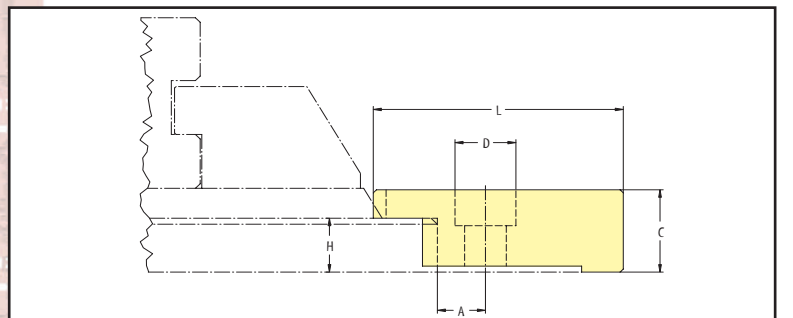

GUIDA RIFERIMENTO/REFERENCE GUIDE SPE. 81

MOD	A	C	D	H	L	F	B
100	14	6	6	12	25	x M6	A Richiesta
125	14	6	6	12	25	x M6	A Richiesta
150	16	6	6	12	25	x M6	A Richiesta
200	16	6	6	12	25	x M6	A Richiesta

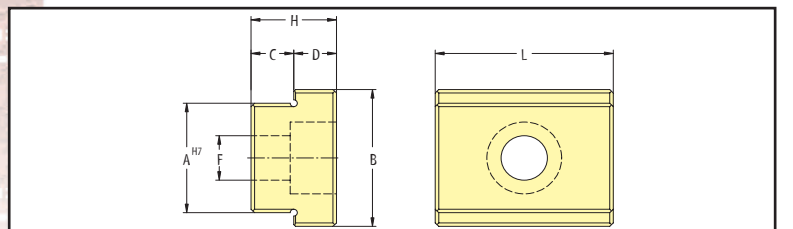

MORSE TIPO / VICES TYPE MIPA. 95



TIPO / TYPE MIPA. 95

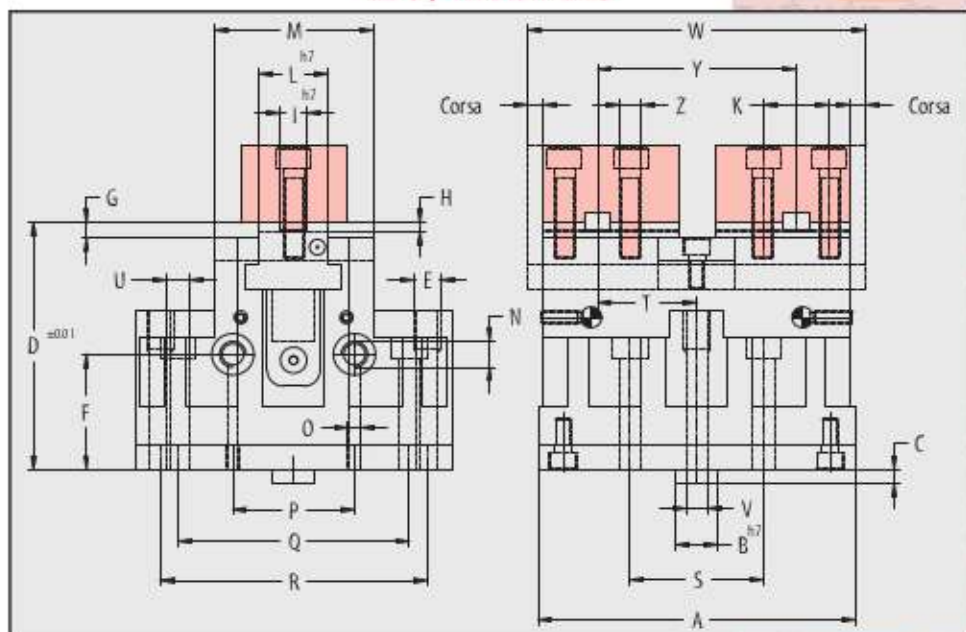

Descrizione	MOD. 90	MOD. 120	MOD. 165
Corsa chiusura	10	12	20
A	88	120	165
B	14	16	25
C	5.5	5.5	5.5
D	77	95	140
E	M8	M10	M12
F	35	44	63
G	5	6	8.5
H	3.5	3.5	4
I	8	10	16
K	20	25	40
L	20	26	40
M	47	60	90
N	M5	1/8	1/4
O	M5	M5	1/8
P	27.2	38.5	48
Q	61.5	87.5	118
R	71	101	136
S	35.5	50.5	68
T	32	43.75	61
U	±6.3	±8.5	±10.5
V	±6	±8	±10
W aperto tutto	98	128.5	182
Y aperto	64	87.5	122
Z	M6	M8	M10
PESO KG.	3	6	16.5
FORZA SERRAGGIO	KGf	KGf	KGf
6 ATM	90	290	490
10 ATM	150	483	816

 La morsa Tipo MIPA. 95, l'attrezzo ideale per bloccare pezzi su macchine a tavola rotante nelle varie posizioni di stazionamento, per lavorazioni meccaniche, assemblaggi o movimento pezzi. Costruita interamente in acciaio al cromo nichel, temprata a 58 HRC, rettificata, assicura la massima precisione, perfetto funzionamento, durata nel tempo illimitata. Inserendo delle ganasce nelle apposite guide, situate nei carri della morsa, si possono bloccare pezzi di svariate forme. Pu funzionare con aria o ad olio fino a 20 Bar. Viene costruita in tre modelli per soddisfare varie richieste.

 The vice type MIPA. 95 is the ideal too to block pieces on rotating table machines in their various stationary positions, for mechanical work, assemblage or movement of pieces. Entirely built in chromium nickel steel, hardened in 58 HRC, rectified, assure max precision, perfect function, unlimited duration. Inserting jaws in proper slides, sited in vice bogie, it's possible to block pieces of various form. Function with air or oil until 20 BAR. Built in three models to satisfy various request.



MORSE TIPO / VICES TYPE GP. 76



BASE GIREVOLE/ROTATING BASE GP. 76

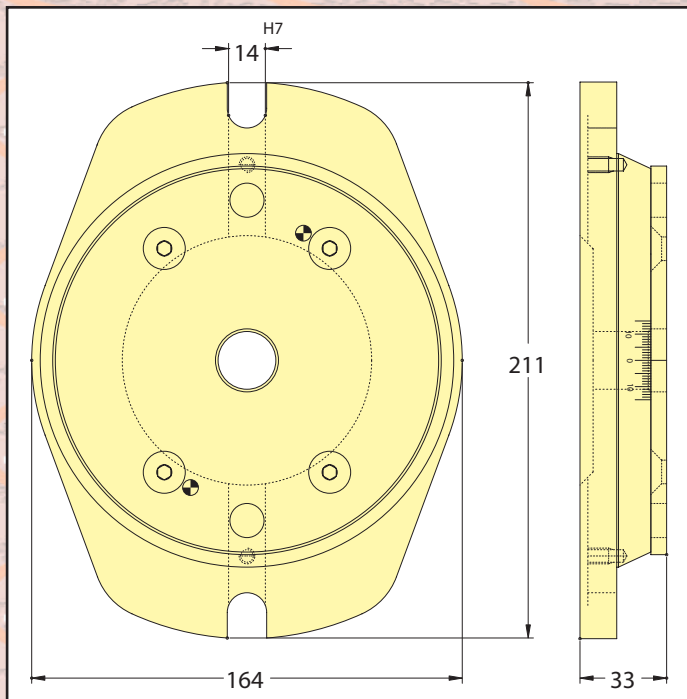

GANASCIA A V/V-JAW GP. 76

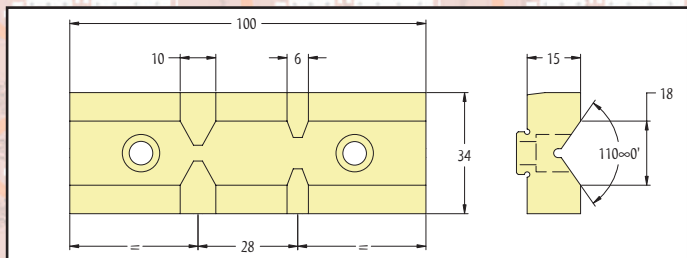

GRUPPO VITE/SCREW UNIT GP. 76

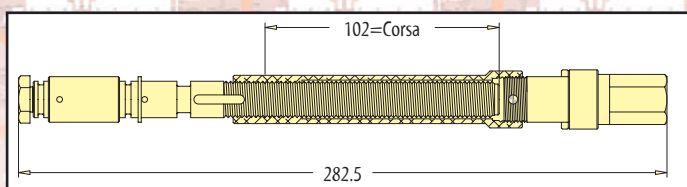

TIPO / TYPE GP. 76

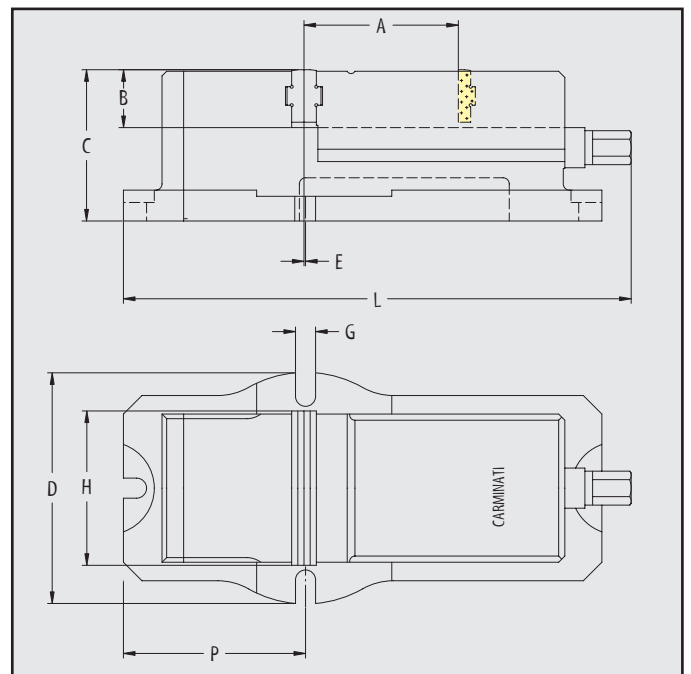

MOD	A	B	C	D	E	G	H	L	P	Peso Kg.
100	100	37.5	98	149	1	13	100	329	118	17.5

Le morse tipo GP76 sono state studiate per lavorazioni di grandi serie. La loro struttura in ghisa G26.

Il funzionamento avviene mediante due pistoni incorporati dei quali uno a doppio effetto.

La corsa pneumatica di mm. 12; la potenza di bloccaggio a 6 BAR di Kg/F 500. Rettificate in tutti i particolari che le compongono garantiscono la massima precisione.

 GP76 PRECISION VICES IN G 26 MECHANICAL CAST IRON WITH PNEUMATIC CLOSURE TYPE GP 76

This vice has been studied for mass working and its structure is in G 26 cast iron. The function is obtained by means of two cylinders that are incorporated in the vice, and of the one has a double effect.

The pneumatic stroke is of 12 mm. Blocking power at 6 ATM is of 500 Kgs. Ground in all its parts it guarantees maximum precision.

MORSE TIPO / VICES TYPE AC. - PIA. 83



TIPO / TYPE AC.

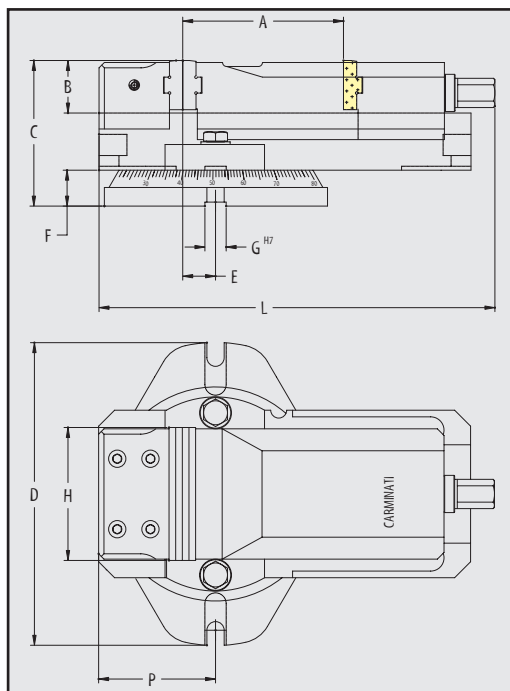

TIPO / TYPE PIA. 83

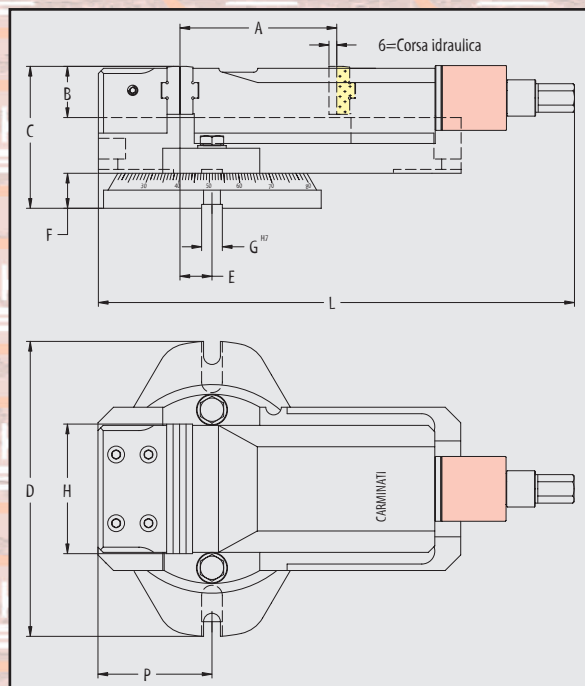

MOD	A	B	C	D	E	F	G	H	L	P	Peso Kg.
100	120	39.5	109.5	228	25	27	14	100	298	88	23
125	140	39.5	116.5	258	37	30	14	125	326	105	32
150	170	45.5	135.5	294	34	34	16	150	396	124	52
200	220	51.5	141.5	358	52	34	16	200	462	144	82
250	345	58.5	162.5	406	69.5	37	16	250	613	180	129

Le morse AC sono interamente costruite in acciaio con guida temperata ad induzione. Tra le caratteristiche principali emergono: l'elevata apertura, l'ingombro limitato in altezza, l'aspetto armonioso e moderno della forma. Rettificate in tutti i particolari che le compongono garantiscono la massima precisione.

Per le morse Tipo AC mod. 100-125-150-200 prevista una chiusura oleopneumatica: sono le morse tipo PIA 83. Mediante il cilindro inserito nella vite e un moltiplicatore di pressione aria-olio possibile un bloccaggio costante e sicuro senza l'affaticamento dell'operatore. Il posizionamento del carro avviene mediante la rotazione della vite con l'apposita manovella. Per il bloccaggio del pezzo sufficiente azionare la valvola del moltiplicatore aria-olio. Corsa oleodinamica di 6 mm.

Forza di bloccaggio con 8 bar di Kg./F 1900 per i modelli 100-125, di Kg./F 3500 per il modello 150 e di 5500 per il modello 200.

PRECISION VICES IN STEEL WITH MECHANICAL CLOSURE TYPE AC

These vices are wholly built in steel with hardened induction guide. Amongst the characteristics of these vices we bring to your notice the harmonious and modern shape, none less the large opening and the limited overall height. Ground in all parts they guarantee maximum precision. an oil-hydraulic closing device is supplied for ac vice models 100-125-150-200: these are the pia 83 type vices. constant, safe locking without tiring the operator is assured by the cylinder fitted on the screw and an air-oil pressure multiplier. the trolley is positioned by rotating the screw with a crank. to lock the piece, one uses the air-oil multiplier valve. oil-hydraulic stroke: 6 mm. locking force at 8 bar for models 100-125: 1900 kg/f; for model 150: 3500 kg/p; for model 200: 5500 kg/p.

MOD	A	B	C	D	E	F	G	H	L	P	Peso Kg.
100	120	39.5	109.5	228	25	27	14	100	367	88	23
125	140	39.5	116.5	258	37	30	14	125	395	105	32
150	170	45.5	135.5	294	34	34	16	150	469	124	52
200	220	51.5	141.5	358	52	34	16	200	549	144	82



COMPONENTI / COMPONENT PARTS AC-PIA. 83

GANASCIA A V / V-JAW AC - PIA. 83

MOD	D	I	L	S	V	V1	V2
100	37	28	100	15	18x110i	6x110i	10x110i
125	37	48	125	15	18x110i	6x110i	10x110i
150	43	60	150	15	18x110i	8x110i	12x110i
200	48	60	200	20	22x110i	11x110i	15x110i
250	56	80	250	20	22x110i	12x110i	16x110i

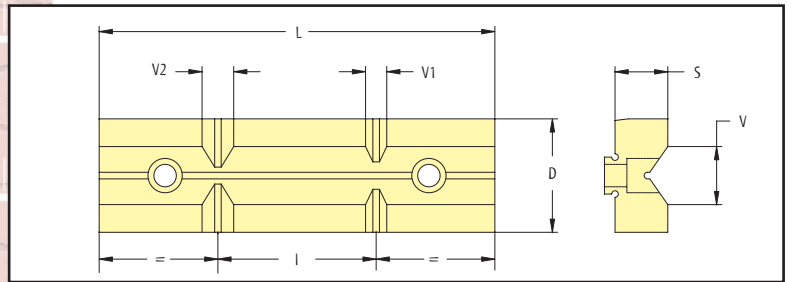

GRUPPO VITE/SCREW UNIT AC

MOD	L	C	F
100	220	121.5	M20
125	240	139	M20
150	286	168.5	M20
200	348	218.5	i24 TpN
250	486	346	i30 TpN

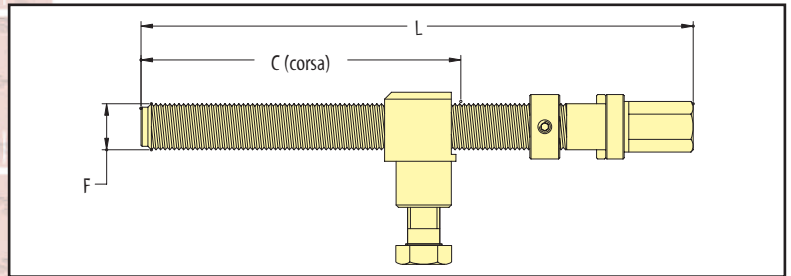

VITE CHIOCCIOLA/SCROLL SCREW PIA 83

MOD	C	F	L	Corsa olio
100	120	M20	288	6
125	139	M20	327	6 12
150	168.5	M20	360	6
200	318.5	i24 TpN	435	6

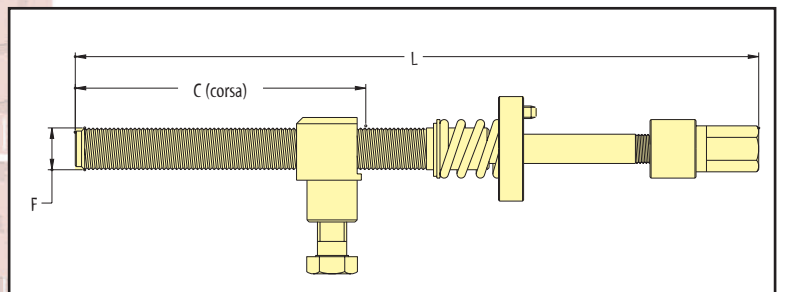

CILINDRO/CYLINDER PIA 83

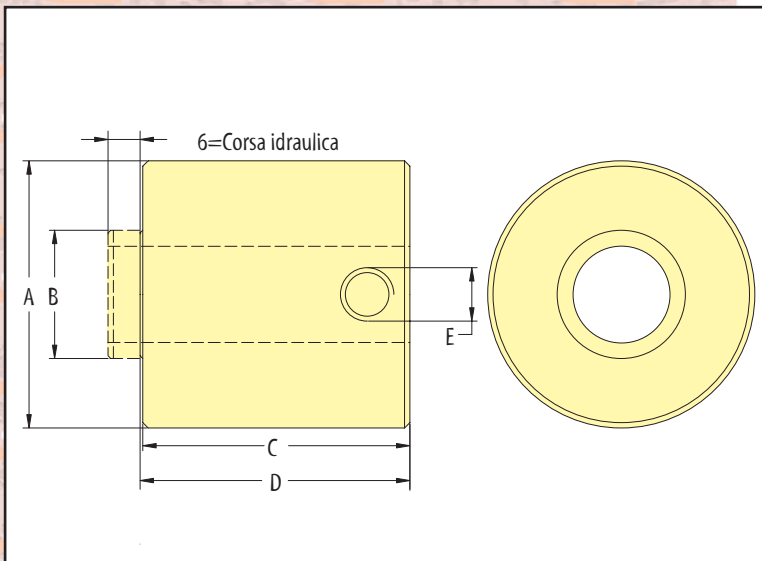

MOD	A	B	C	D	E
100	i50	i24	50	50.5	1/8
125	i50	i24	50	50.5	1/8
150	i70	i35	52	52.5	1/8
200	i83	i40	62	62.5	1/4

BASE GIREVOLE/ ROTATING BASE AC - PIA 83

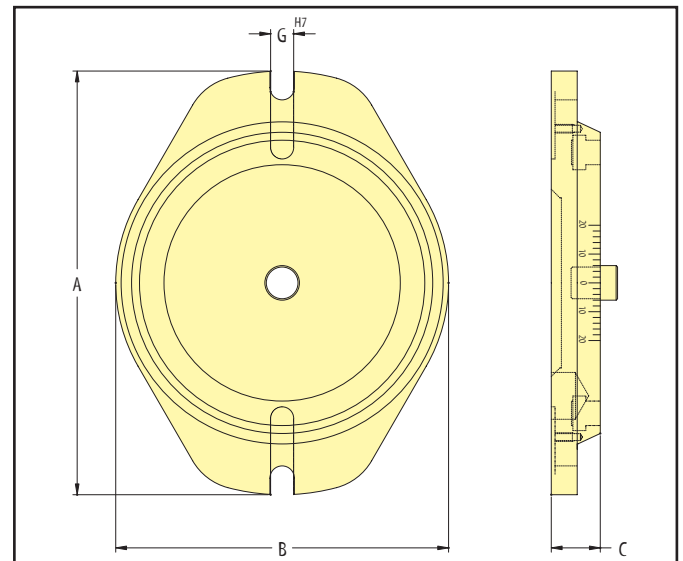

MOD	A	B	C	G
100	220	168	27	14
125	250	202	30	14
150	294	231	34	16
200	358	295	34	16
250	407	349	38	16

MORSE TIPO / VICES TYPE GM. 75 - FIG. 83



TIPO / TYPE GM. 75

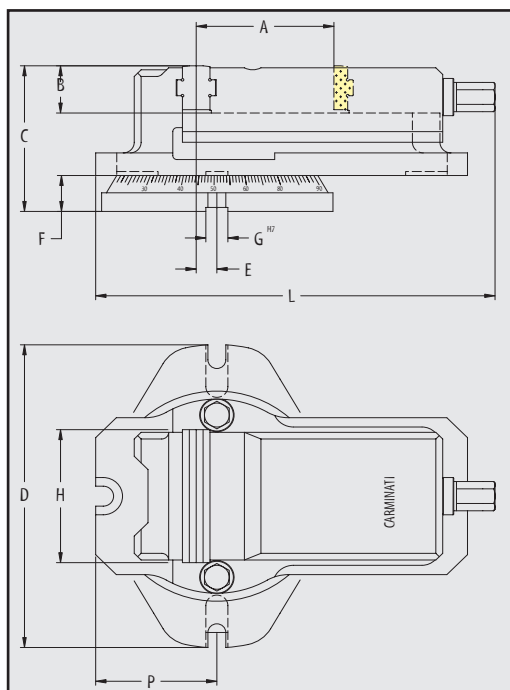

MOD	A	B	C	D	E	F	G	H	L	P	Peso Kg.
100	100	35.5	109.5	228	15	27	14	100	290	88	17
120	120	39.5	115.5	238	18	28	14	120	327	98	23
150	150	45.5	126.5	294	46	34	16	150	390	130	36
200	200	51.5	139.5	358	51	34	16	200	471	155	62

La singolare struttura di queste morse in ghisa sferoidale avente un carico di rottura di 50/55 Kg/mm² con allungamento del 7%.

Le caratteristiche del materiale impiegato vengono esaltate anche da un particolare trattamento termico che gli conferisce elevata tenacità e resistenza all'usura.

Rettificate in tutti i particolari che le compongono garantiscono la massima precisione. Per le morse a chiusura meccanica tipo GM75 modelli 100, 120, 150, 200 prevista una chiusura oleopneumatica: sono le morse tipo FIG83.

Mediante il cilindro inserito nella vite ed un moltiplicatore di pressione aria-olio possibile un bloccaggio sicuro senza affaticamento dell'operatore.

Il posizionamento del carro avviene mediante la rotazione della vite con l'apposita manovella. Per il bloccaggio del pezzo sufficiente azionare la valvola del moltiplicatore aria-olio.

La corsa oleodinamica di mm 6.

La forza di bloccaggio con 8 BAR di Kg/F 1900 per i modelli 100 e 120, di Kg/F3500 per il modello 150 e di Kg/F 5500 per il modello 200.

Rettificate in tutti i particolari che le compongono garantiscono la massima precisione.

 GM75 PRECISION VICES IN 50/5 SPHEROIDAL CAST IRON WITH MECHANICAL CLOSURE TYPE GM75

The singular structure of these vices in spheroidal cast iron with breakage strain of 50/55 Kgs.mm² with 7% lengthening. The characteristics of the material used are boasted by a particular treatment that gives it a high standard of toughness and resistance to wear. Ground in all their parts they guarantee maximum precision.

FIG 83 PRECISION VICES WITH OLEOPNEUMATIC CLOSURE WITH SEPARATED AIR-OIL MULTIPLIER TYPE FIG. 83

For our vices with mechanical closure type GM75 - 100- 120 - 150 - 200 it is also foreseen an oil-pneumatic closure.

Through a hydraulic cylinder set in the screw and an air-oil pressure multiplier a safe blocking operation is possible without stress by the operator.

The set of saddle happens by means of the screw rotation through the winch.

For blocking the piece act on the lever put on the air-oil multiplier 6 mm Oleopneumatic stroke. Blocking power at 8 bar

Kgs. 1900 (by type 100 and 120) - Kgs. 3500 (by type 150) - Kgs. 5500 (by type 200).

TIPO / TYPE FIG. 83

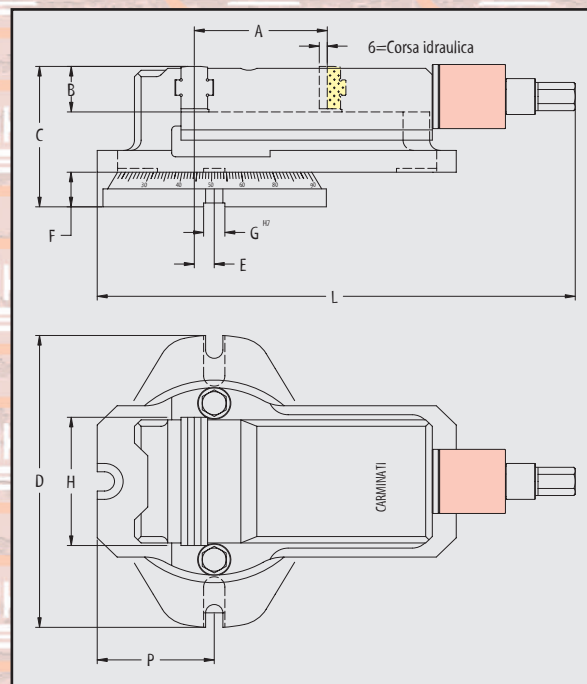

MOD	A	B	C	D	E	F	G	H	L	P	Peso Kg.
100	100	35.5	109.5	228	15	27	14	100	359	88	18.5
120	120	39.5	115.5	238	18	28	14	120	396	98	24.5
150	150	45.5	126.5	294	46	34	16	150	463	130	38
200	200	51.5	139.5	358	51	34	16	200	558	155	64.5



COMPONENTI / COMPONENT PARTS GM. 75-PIG 83

GANASCIA A V/V-JAW GM. 75 - FIG. 83

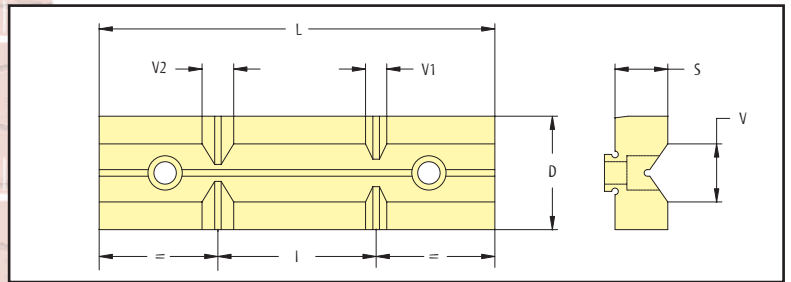

MOD	D	I	L	S	V	V1	V2
100	33	28	100	15	18x110i	6x110i	10x110i
120	37	48	120	15	18x110i	6x110i	10x110i
150	43	60	150	15	18x110i	8x110i	12x110i
200	48	60	200	20	22x110i	11x110i	15x110i

GRUPPO VITE/SCREW UNIT GM.75

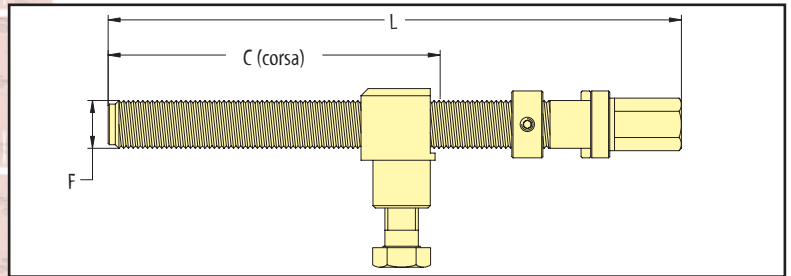

MOD	C	F	L
100	98	M20	202
120	119	M20	230
150	151.5	M20	286
200	201.5	i24 TpN	348

GRUPPO VITE/SCREW UNIT FIG. 83

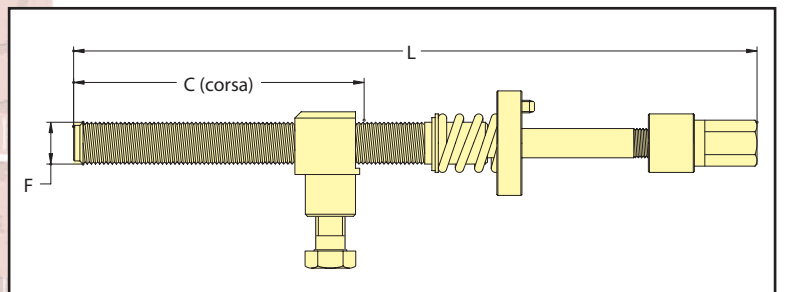

MOD	C	F	L	Corsa olio
100	97	M20	271.5	6
120	119	M20	299.5	6 12
150	151.5	M20	359.5	6
200	201.5	i24 TpN	435	6

CILINDRO/CYLINDER FIG. 83

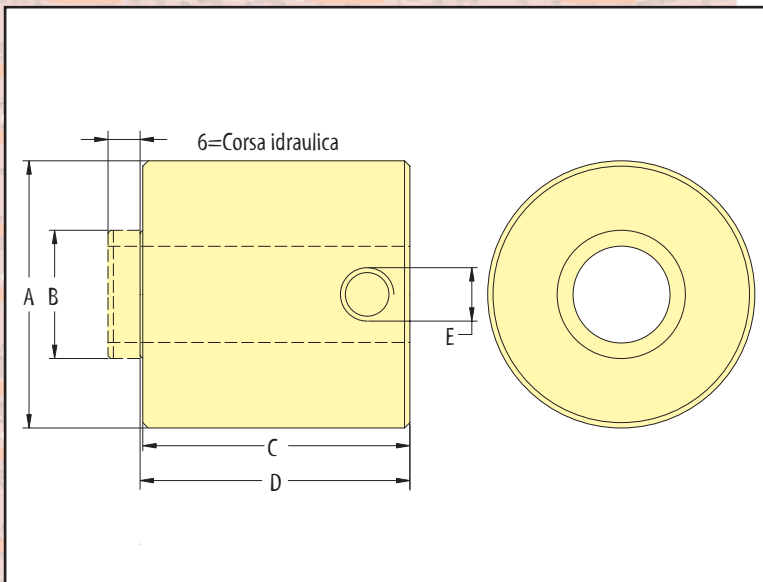

MOD	A	B	C	D	E
100	i50	i24	50	50.5	1/8
125	i50	i24	50	50.5	1/8
150	i70	i35	52	52.5	1/8
200	i83	i40	62	62.5	1/4

BASE GIREVOLE/ROTATING BASE GM. 75 - FIG. 83

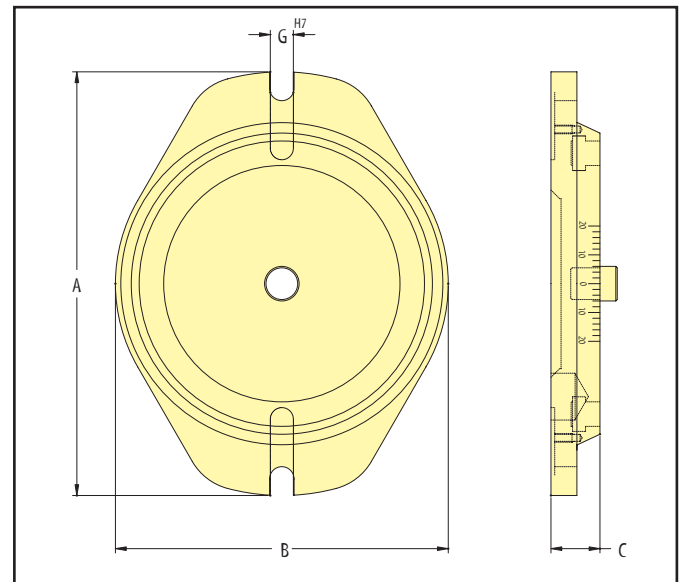

MOD	A	B	C	G
100	220	168	27	14
120	238	185	28	14
150	294	231	34	16
200	358	295	34	16

MORSE TIPO / VICES TYPE PR. 79

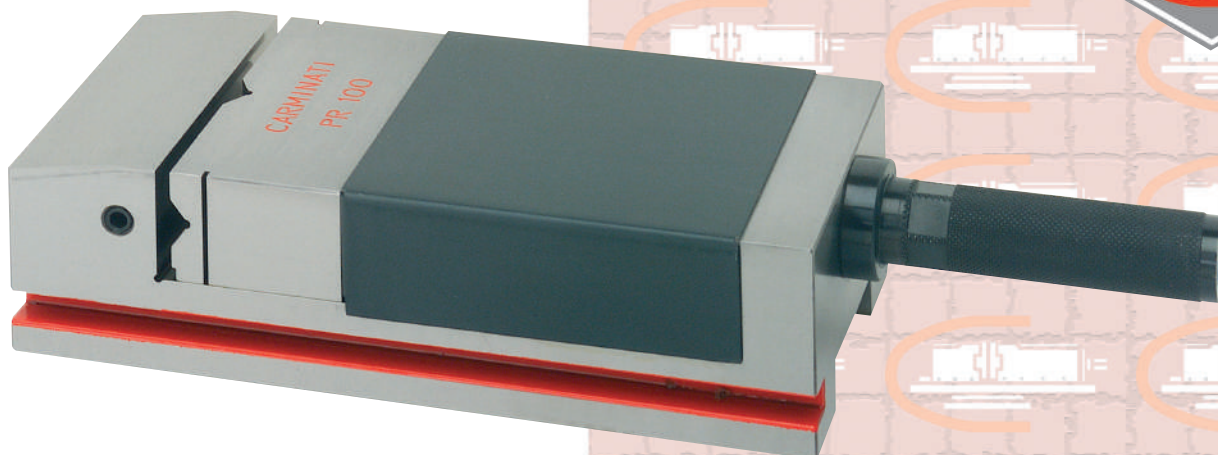

TIPO / TYPE PR. 79

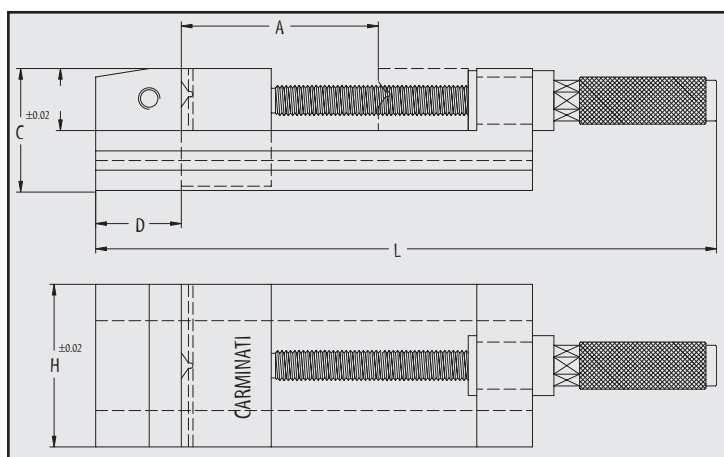

MOD	A	B	C	D	H	L	Peso Kg.
80	82	29	57	40	76	290	5
100	102	36	67	46	96	344	8

GRUPPO VITE / SCREW UNIT PR. 79

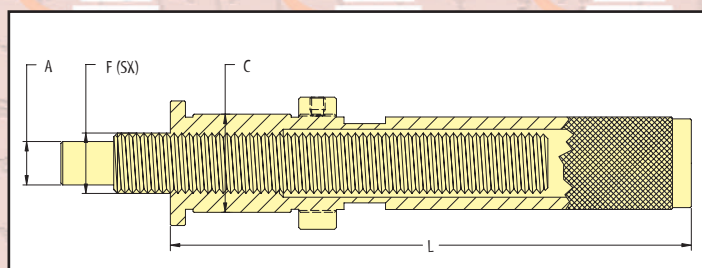

MOD	A	C	F	L
80	11.5	∅22	∅14 TpN	116
100	11.5	∅26	∅16 TpN	138

 Le morse tipo PR79 vengono rerealizzate con un elevato grado di precisione $-0,01$.

Sono costruite completamente in acciaio al nichel temperato. Indefornabile e rettificato su tutti i loro piani permettono di ottenere la perfetta ortogonalit su qualsiasi piano desiderato.

 PR79 PRECISION VICES FOR GRINDING IN HARDENED STEEL TYPE PR 79 These vices are made with a high standard of precision $-0,01$.

Completely built in hardened steel, indeformable and ground at all surface allowing to obtain perfect orthogonality of any disordered surface.



MANDRINO M.T. 88

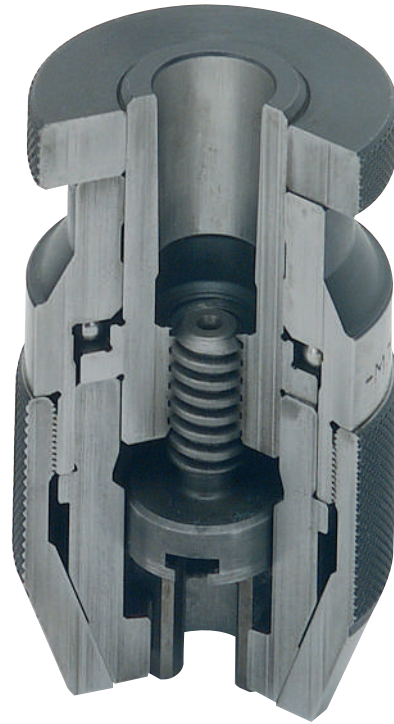

MANDRINO MT. 88

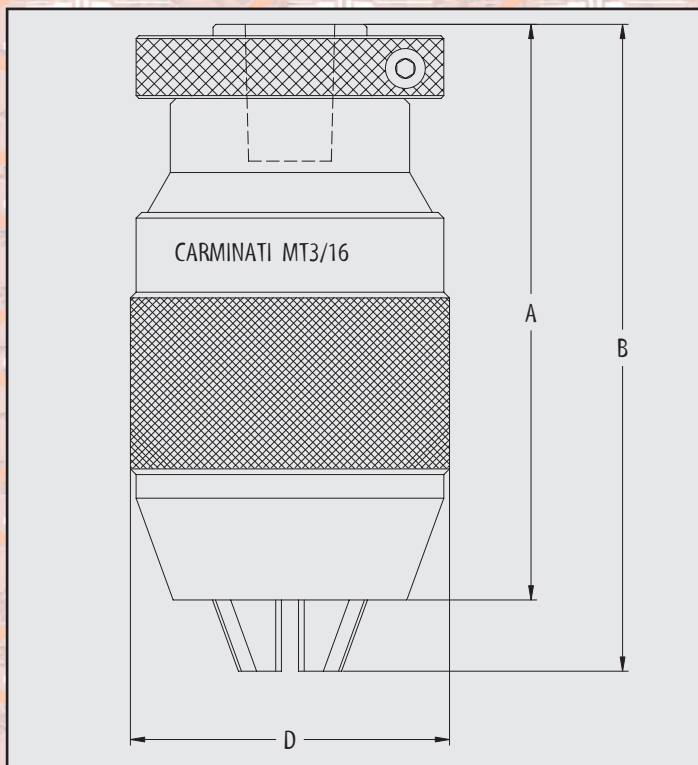

 I mandrini portapunte Carminati tipo MT.88 sono interamente costruiti in acciaio al nichel temperato. Rettificati in tutti i particolari che li compongono, garantiscono la massima precisione. Vengono prodotti in quattro modelli.

 MANDRINO M.T. 88 The Carminati mandrel type MT.88 is wholly made in hardened nickel steel. Ground in all parts they guarantee maximum precision. They come in four models.

MOD	DIAMETRO D	LUNGHEZZA A	LUNGHEZZA B	CONO INTER DIN	PESO GR
0÷8	37	76	84	B10-B12	470
1÷13	44	91	102	B12-B16	675
3÷16	56	101	113.5	B13-B18	1350
5÷20	64	108	122	B18	1600

PARALLELE PER MORSE / PARALLEL BARS FOR VICES

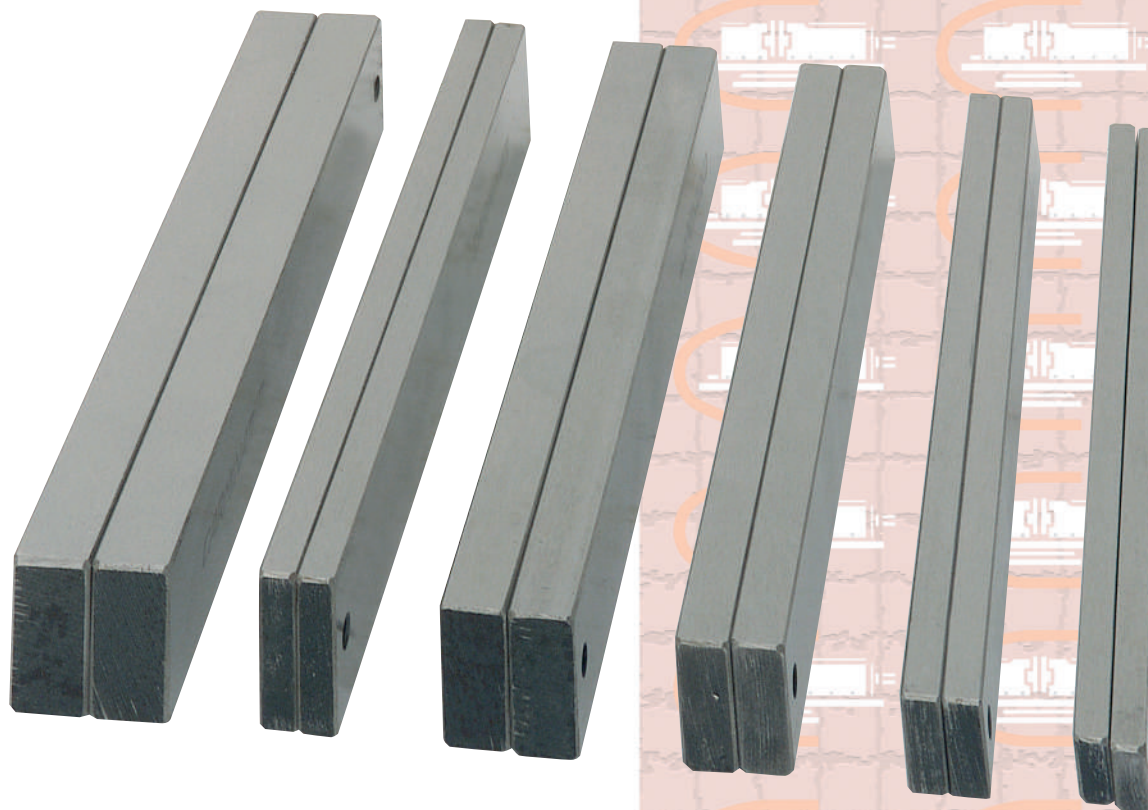

LARGHEZZA	10	15	20	22	25	25
SPESSORE	5	6	8	10	12	6
LUNGHEZZA TOT.	155					
PESO KG.	2,350					

 Sono costituite in acciaio temperato, stabilizzato e rettificato assicurando così una notevole precisione.

Con le loro combinazioni si possono ottenere elevati valori di misure desiderate. Vengono fornite con custodia di legno per ripararle da eventuali ammaccature cui possono essere soggette.

PARALLEL BARS FOR VICES

These parallel bars, built with tempered, stabilized and rectified steel, allow a considerable precision.

Combining them, a variety of measures can be obtained. They are supplied in a wooden case to prevent possible dents.

Dimensions are approximate.

MOLTIPLICATORE ARIA OLIO

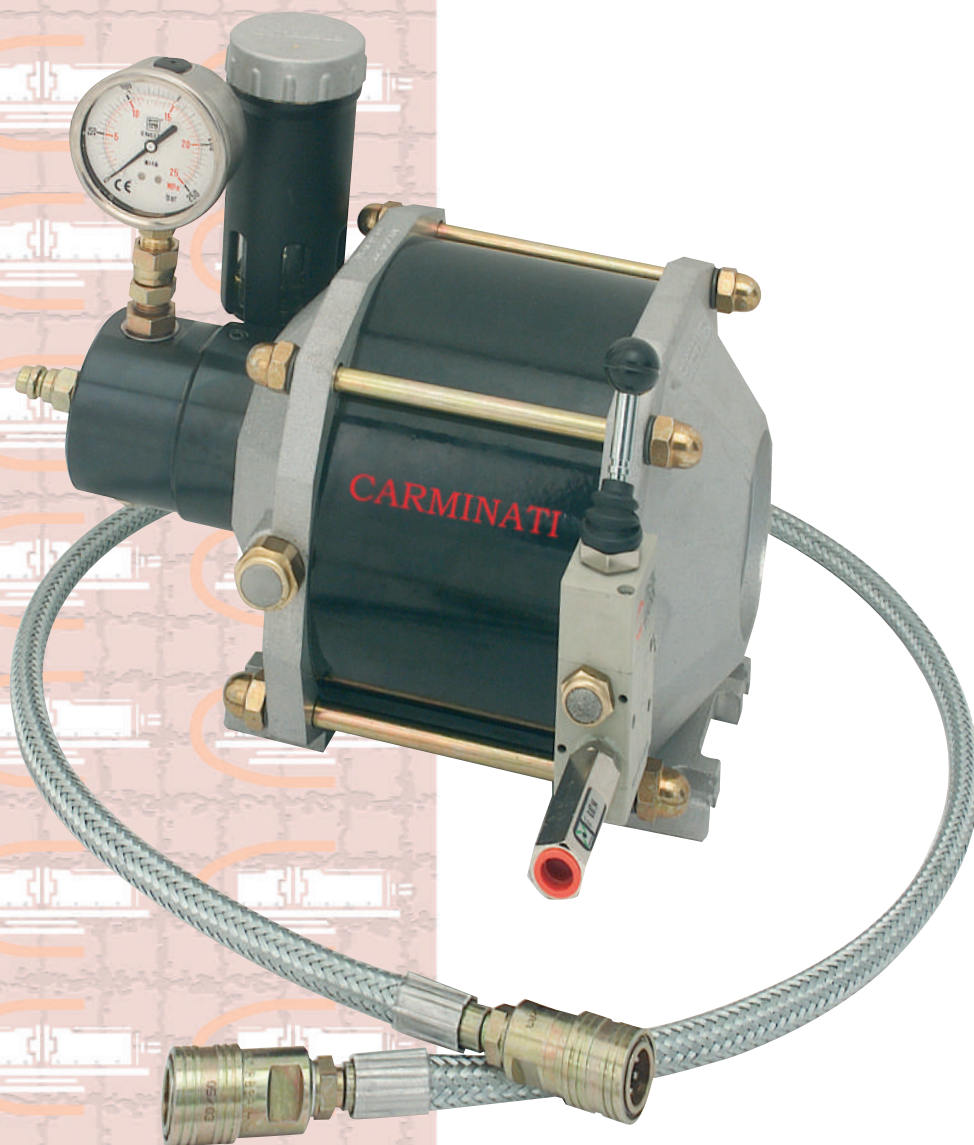

 Il moltiplicatore di pressione aria-olio della CARMINATI MORSE è un organo pompante avente un circuito idraulico chiuso a semplice effetto collegato a un contenitore d'olio per il ripristino automatico ad ogni corsa, di piccole perdite e trafilamenti.

Il funzionamento avviene immettendo aria nel circuito pneumatico dall'entrata.

Si possono avere con il ritorno a molla tipo RM o in doppio effetto tipo RP.

La pressione dell'olio in uscita è variabile, tramite la regolazione dell'aria in entrata vengono forniti completi di valvola pneumatica, manometro e turbo AP con attacchi rapidi e lunghezza standard di mm 1200, pronti per l'utilizzo con le morse CARMINATI. Il rapporto della pressione è di 1/25 e si possono avere con varie portate a seconda del numero di morse che si vuole azionare contemporaneamente?

Mod 100

Mod 160

Mod 200

 The air-oil pressure multiplier of carminati vices is a pumping unit with a single-acting closed hydraulic circuit, connected to an oil container. The multiplier automatically tops up small losses and leaks at every stroke.

It operates by delivering air to the pneumatic circuit from the entry point.

The multiplier is available either with the RM type return spring, or as the double-acting RP type.

Oil pressure can be varied at outlet, by adjusting entering air. The multipliers are supplied complete with pneumatic valve, pressure gauge and AP turbo, with rapid attachments and standard length of 1200 mm, ready for use with carminati vices. Pressure ratio is 1/25. Can be supplied at different capacity levels according to the number of vices to be activated simultaneously.

mod 100

mod 160

mod 200



La società Carminati è a disposizione della gentile clientela per fornire ulteriori informazioni sulle specifiche tecniche dei suoi prodotti



The Carminati Company is at disposition for the customers to specify further technical informations of their products



**CARMINATI
MORSE**

CARMINATI MORSE - 25136 BRESCIA - ITALY - VIA DEL BROLO, 28 - TEL. 0302008315 - FAX 0302002057
www.carminatimorse.it - e-mail: carminatimorse@carminatimorse.it